

Key: 1890

Town of SCITUATE - Fiscal Year 2024

10/18/2023 5:31 pm SEQ #: 1.817

LEGAL

LAND

DETACHED

BUILDING

CURRENT OWNER				PARCEL ID				LOCATION			
NUGENT MARTHA TR 568 FIRST PARISH RD SCITUATE, MA 02066				31-1-39-0				568 FIRST PARISH RD			
TRANSFER HISTORY				DOS	T	SALE PRICE	BK-PG (Cert)				
NUGENT MARTHA TR				08/13/2007	F	1	34945-328/30				
NUGENT JAMES W & MARTHA				01/01/1978	QS		4278-541				
FORD WILLIAM F TRUSTEE				01/01/1974	XX		3889-183				

CLASS	CLASS%	DESCRIPTION			BN ID	BN	CARD	
1010	100	SINGLE FAMILY				1	1 of 1	
PMT NO	PMT DT	TY	DESC	AMOUNT	INSP	BY	1st	%
19-235	06/06/2019	5	SPLIT/SUB/LA		04/08/2020	JD	100	100
19-382	05/24/2019	1	NEW CONST	400,000	06/04/2019	TCK	100	0
SS15-02		5	SPLIT/SUB/LA		03/13/2014	SJ	100	100
	02/06/2013	7	OTHERS	15,000	08/28/2013	SJ	100	100
		5	SPLIT/SUB/LA		05/19/2005	SJ	0	100

CD	T	AC/SF/UN	Ngh	Inf1	Inf2	ADJ BASE	SAF	Inf3	Lpi	VC	CREDIT AMT	ADJ VALUE
100	S	40,000	WS 1.00	100	1.00	374,000	1.00	100	1.00	R03	0.85	343,430
300	A	9,367	WS 1.00	100	1.00	16,830	0.56	100	1.00	R03	0.85	87,820

TOTAL	10.285 Acres		ZONING	FRNT	193	ASSESSED	CURRENT	PREVIOUS
Ngh	W. SCITUATE		NOTE C/W 40 41...27 28 29			LAND	431,300	396,500
Inf1	FACTOR 100			BUILDING	256,900	239,000		
Inf2	PHY 100			DETACHED	100	100		
				OTHER	0	0		
					TOTAL	688,300	635,600	

TY	QUAL	COND	DIM/NOTE	YB	UNITS	ADJ PRICE	RCNLD
S/V	A	1.00	SV 1.00 SHED		100	1.10	100



BUILDING	CD	ADJ	DESC	MEASURE	8/19/2010	PL
MODEL	1		RESIDENTIAL	LIST	8/19/2010	EST
STYLE	4	1.10	CAPE [100%]	REVIEW	6/4/2019	TCK
QUALITY	+	1.10	AVG +/GOOD - [100%]			
FRAME	1	1.00	WOOD FRAME [100%]			

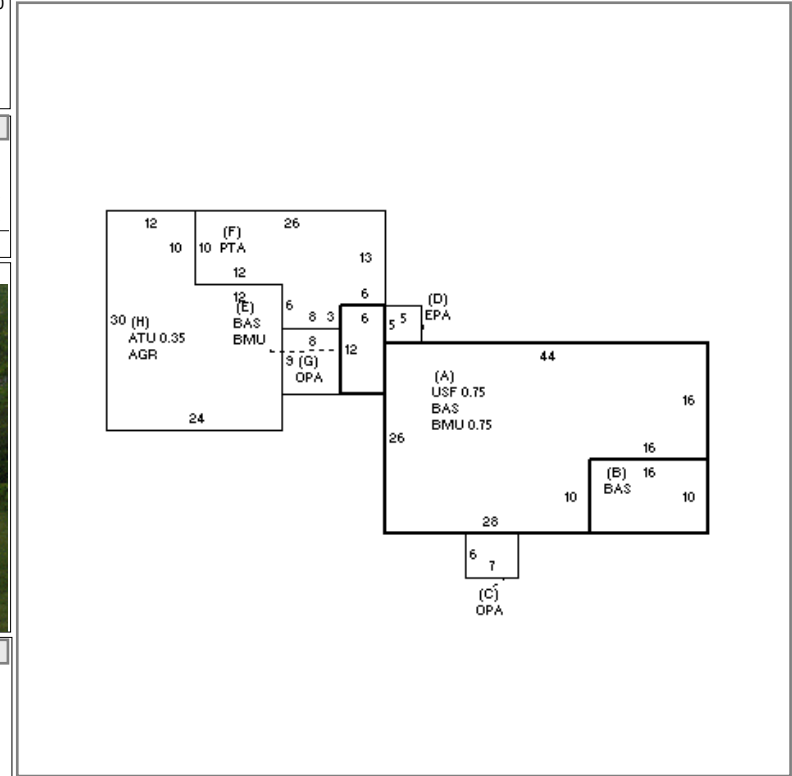

YEAR BLT	1940	SIZE ADJ	1.000	ELEMENT	CD	DESCRIPTION	ADJ	S	BAT	T	DESCRIPTION	UNITS	YB	ADJ PRICE	RCN
NET AREA	1,954	DETAIL ADJ	1.122	FOUNDATION	5	BRICK/STONE	1.00	+	BMU	N	BSMT UNFINISHED	810		55.34	44,826
\$NLA(RCN)	\$299	OVERALL	1.000	EXT COVER	1	WD SHINGLES	1.00	A	USF	L	UPPER STORY FIN	738	1940	227.13	167,624
				ROOF SHAPE	1	GABLE	1.00	+	BAS	L	BASE AREA	1,216	1940	249.76	303,711
				ROOF COVER	1	ASPH SHINGLES	1.00	+	OPA	N	OPEN PORCH	114		56.65	6,458
				FLOOR COVER	99	N/A	1.00	D	EPA	N	ENCLOSED PORCH	25		99.22	2,481
				INT FINISH	99	N/A	1.00	F	PTA	N	PATIO	326		16.39	5,343
				HEATING/COOLING	2	HOT WATER	1.02	H	AGR	N	ATT GARAGE	600		46.47	27,884
				FUEL SOURCE	99	N/A	1.00	H	ATU	N	ATTIC UNF	210		40.70	8,547
									F21	O	FPL 2S 1OP	1		9,062.90	9,063

TOTAL RCN	583,835	
CONDITION ELEM CD		
EXTERIOR		
INTERIOR		
KITCHEN		
BATHS		
HEAT		
ELECT		
EFF.YR/AGE 1956 / 66		
COND	56	56 %
FUNC	0	
ECON	0	
DEPR	56	% GD 44
RCNLD	\$256,900	