

Key: 1979

Town of SCITUATE - Fiscal Year 2024

10/18/2023 5:31 pm SEQ #: 1.903

LEGAL

CURRENT OWNER				PARCEL ID				LOCATION			
DARCI SCOTT & TESS 111 OLD OAKEN BUCKET RD SCITUATE, MA 02066				47-1-3-0				111 OLD OAKEN BUCKET RD			
TRANSFER HISTORY				DOS	T	SALE PRICE	BK-PG (Cert)				
DARCI SCOTT & TESS				07/21/2020	QS	1,310,000	53111-316				
WEBB BUILDERS, INC				11/06/2014	P	255,000	44919-215				
POPE'S POND CRANBERRY CO				08/02/1991	QS	800,000	10413-329				

CLASS	CLASS%	DESCRIPTION			BN ID	BN	CARD	
1010	100	SINGLE FAMILY				1	1 of 1	
PMT NO	PMT DT	TY	DESC	AMOUNT	INSP	BY	1st	%
14-137	12/08/2014	1	NEW CONST	230,000	06/08/2015	SJ	100	50
14-137	12/08/2014	1	NEW CONST	230,000	05/17/2016	SJ	100	100
		5	SPLIT/SUB/LA				100	100
		5	SPLIT/SUB/LA				100	100

LAND

CD	T	AC/SF/UN	Ngh	Inf1	Inf2	ADJ BASE	SAF	Inf3	Lpi	VC	CREDIT AMT	ADJ VALUE
100	S	40,000	WS 1.00	100	1.00	374,000	1.00	100	1.00	R03	0.85	343,430
300	A	0.750	WS 1.00	100	1.00	16,830	1.00	100	1.00	R03	0.85	12,620

TOTAL	1.668 Acres	ZONING	FRNT	149	ASSESSED	CURRENT	PREVIOUS
Ngh	W. SCITUATE	NOTE LPI changed to R03 FY22	LAND		356,100	324,300	324,300
Inf1	FACTOR 100		BUILDING		1,583,300	1,321,600	1,321,600
Inf2	PHY 100		DETACHED		0	0	0
			OTHER		0	0	0
			TOTAL		1,939,400	1,645,900	1,645,900

DETACHED

TY	QUAL	COND	DIM/NOTE	YB	UNITS	ADJ PRICE	RCNLD	PHOTO	06/22/2020

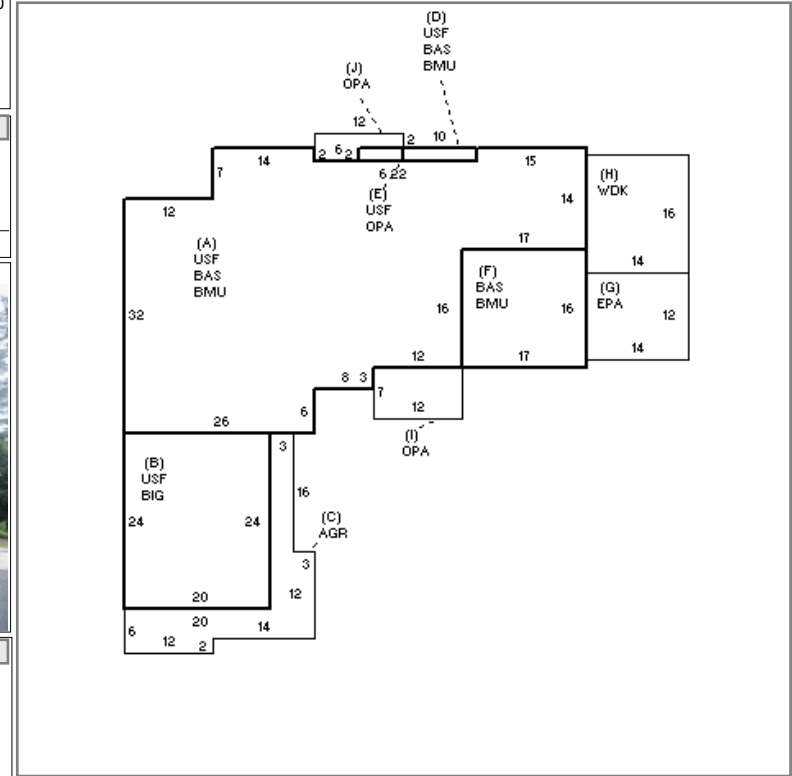

BUILDING

BUILDING	CD	ADJ	DESC	MEASURE	6/22/2020	JD	BLDG COMMENTS
MODEL	1		RESIDENTIAL	LIST	6/22/2020	EST	xtra shower and sink
STYLE	20	1.35	NEW STYLE [100%]	REVIEW	2/7/2021	JD	MLS
QUALITY	V	1.40	VERY GOOD [100%]				
FRAME	1	1.00	WOOD FRAME [100%]				

YEAR BLT	2016	SIZE ADJ	1.000	ELEMENT	CD	DESCRIPTION	ADJ	S	BAT	T	DESCRIPTION	UNITS	YB	ADJ PRICE	RCN	TOTAL RCN	1,684,323
NET AREA	4,300	DETAIL ADJ	1.390	FOUNDATION	3	CONT WALL	1.00	+	BMU	N	BSMT UNFINISHED	2,040		56.41	115,067		
\$NLA(RCN)	\$392	OVERALL	1.000	EXT COVER	2	CLAPBOARD	1.00	+	BAS	L	BASE AREA	2,040	2016	353.61	721,358		
				ROOF SHAPE	1	GABLE	1.00	+	USF	L	UPPER STORY FIN	2,260	2016	321.57	726,743		
				ROOF COVER	1	ASPH SHINGLES	1.00	B	BIG	N	BUILT-IN GARAGE	480		79.64	38,227		
				FLOOR COVER	12	COMB	1.00	C	AGR	N	ATT GARAGE	424		57.29	12,834		
				INT FINISH	1	PLASTER	1.00	+	OPA	N	OPEN PORCH	132		72.10	9,517		
				HEATING/COOLING	9	WARM/COOL AIR	1.03	G	EPA	N	ENCLOSED PORCH	168		126.28	21,216		
				FUEL SOURCE	2	GAS	1.00	H	WDK	N	WOOD DECK	224		53.76	12,043		
									F11	O	FPL 1S 1OP	1		10,193.40	10,193		

CONDITION ELEM	CD
EXTERIOR	A
INTERIOR	A
KITCHEN	A
BATHS	A
HEAT	A
ELECT	A

EFF. YR/AGE	2016 / 6
COND	6 6 %
FUNC	0
ECON	0
DEPR	6 % GD 94
RCNLD	\$1,583,300