

Key: 2016

Town of SCITUATE - Fiscal Year 2024

10/18/2023 5:31 pm SEQ #: 1.941

LEG
A
L

CURRENT OWNER				PARCEL ID				LOCATION			
MCMURRER ERIN M & DONAHUE PATRICK J 67 OLD OAKEN BUCKET RD SCITUATE, MA 02066				52-2-44-0				67 OLD OAKEN BUCKET RD			
TRANSFER HISTORY				DOS	T	SALE PRICE	BK-PG (Cert)				
MCMURRER ERIN M & MCMURRER ERIN				05/20/2020	F	1	52784-82				
				03/30/2017	QS	470,000	48256-244				
MCLAUGHLIN MADELINE A TR				01/13/2014	F	1	43998-315				

CLASS	CLASS%	DESCRIPTION			BN ID	BN	CARD	
1090	100	MULTIPLE HSES				1	1 of 2	
PMT NO	PMT DT	TY	DESC	AMOUNT	INSP	BY	1st	%
21-487	05/11/2021	1	NEW CONST	97,436	08/12/2021	JD	100	99
21-487	05/11/2021	1	NEW CONST	97,436	08/08/2022	JD	100	100
20-835	11/24/2020	4	DEMO	5,000	05/10/2021	JD	100	100
89-64	03/02/1989	3	ALTERATIONS				100	100
93	08/01/1965	3	ALTERATIONS	110,293			100	100

L
A
N
D

CD	T	AC/SF/UN	Ngh	Inf1	Inf2	ADJ BASE	SAF	Inf3	Lpi	VC	CREDIT AMT	ADJ VALUE
100	S	40,000	WS 1.00	100	1.00	374,000	1.00	100	1.00	R03	0.85	343,430
300	A	0.024	WS 1.00	100	1.00	16,830	1.00	100	1.00	R03	0.85	400

TOTAL	41,034 SF	ZONING	FRNT	384	ASSESSED	CURRENT	PREVIOUS
Ngh	W. SCITUATE	N O T E			LAND	343,800	312,600
Inf1	FACTOR 100		BUILDING	333,600	296,800		
Inf2	PHY 100		DETACHED	0	0		
			OTHER	217,600	195,500		
			TOTAL	895,000	804,900		

D
E
T
A
C
H
E
D

TY	QUAL	COND	DIM/NOTE	YB	UNITS	ADJ PRICE	RCNLD

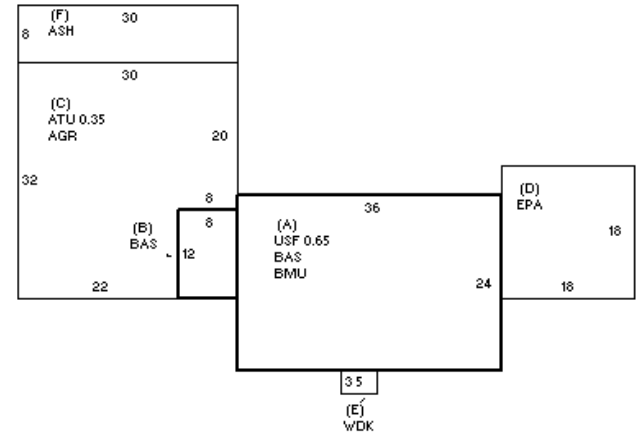

B
U
I
L
D
I
N
G

BUILDING	CD	ADJ	DESC	MEASURE	5/10/2021	JD
MODEL	1		RESIDENTIAL	LIST	5/10/2021	JD
STYLE	4	1.10	CAPE [100%]	REVIEW	8/8/2022	JD
QUALITY	A	1.00	AVERAGE [100%]			
FRAME	1	1.00	WOOD FRAME [100%]			

BLDG COMMENTS

LEGAL ACCESSORY DWELLING #67

YEAR BLT	1958	SIZE ADJ	1.000	ELEMENT	CD	DESCRIPTION	ADJ	S	BAT	T	DESCRIPTION	UNITS	YB	ADJ PRICE	RCN	TOTAL RCN	490,635		
NET AREA	1,522	DETAIL ADJ	1.122	FOUNDATION	4	CONT BSMT WALL	1.00	A	BMU	N	BSMT UNFINISHED	864		49.26	42,558	CONDITION ELEM	CD		
\$NLA(RCN)	\$322	OVERALL	1.000	EXT COVER	1	WD SHINGLES	1.00	A	USF	L	UPPER STORY FIN	562	1958	217.45	122,209	EXTERIOR	A		
				ROOF SHAPE	1	GABLE	1.00	+	BAS	L	BASE AREA	960	1958	239.12	229,555	INTERIOR	A		
				ROOF COVER	1	ASPH SHINGLES	1.00	C	AGR	N	ATT GARAGE	864		39.47	34,102	KITCHEN	A		
				FLOOR COVER	24	COMB	1.00	C	ATU	N	ATTIC UNF	302		37.00	11,174	BATHS	A		
				INT FINISH	1	PLASTER	1.00	D	EPA	N	ENCLOSED PORCH	324		90.20	29,225	HEAT	A		
				HEATING/COOLING	2	HOT WATER	1.02	E	WDK	N	WOOD DECK	15		38.40	576	ELECT	U		
				FUEL SOURCE	1	OIL	1.00	F	ASH	N	ATT SHED	240		18.94	4,545				
									F22	O	FPL 2S ZOP	1		11,305.00	11,305				
CAPACITY		UNITS	ADJ															EFF.YR/AGE	1971 / 51
STORIES		1.65	1.00															COND	32 32 %
ROOMS		5	1.00															FUNC	0
BEDROOMS		2	1.00															ECON	0
BATHROOMS		2	1.00															DEPR	32 % GD 68
# 1/2 BATHS		0	1.00															RCNLD	\$333,600
TOT FIXTURES		6	\$5,386																
# UNITS		1	1.00																

Key: 2016

Town of SCITUATE - Fiscal Year 2024

10/18/2023 5:31 pm SEQ #: 1.942

LEGAL

CURRENT OWNER		PARCEL ID	LOCATION			
MCMURRER ERIN M & DONAHUE PATRICK J 67 OLD OAKEN BUCKET RD SCITUATE, MA 02066		52-2-44-0	67 OLD OAKEN BUCKET RD			
TRANSFER HISTORY		DOS	T	SALE PRICE	BK-PG (Cert)	

CLASS	CLASS%	DESCRIPTION			BN ID	BN	CARD	
1090	100	MULTIPLE HSES				2	2 of 2	
PMT NO	PMT DT	TY	DESC	AMOUNT	INSP	BY	1st	%

LAND

CD	T	AC/SF/UN	Ngh	Inf1	Inf2	ADJ BASE	SAF	Inf3	Lpi	VC	CREDIT AMT	ADJ VALUE
----	---	----------	-----	------	------	----------	-----	------	-----	----	------------	-----------

TOTAL	ZONING	FRNT	ASSESSED	CURRENT	PREVIOUS
Ngh	NOTE		LAND	217,600	
Inf1			BUILDING		
Inf2			DETACHED		
			OTHER		
			TOTAL		

DETACHED

TY	QUAL	COND	DIM/NOTE	YB	UNITS	ADJ PRICE	RCNLD
----	------	------	----------	----	-------	-----------	-------

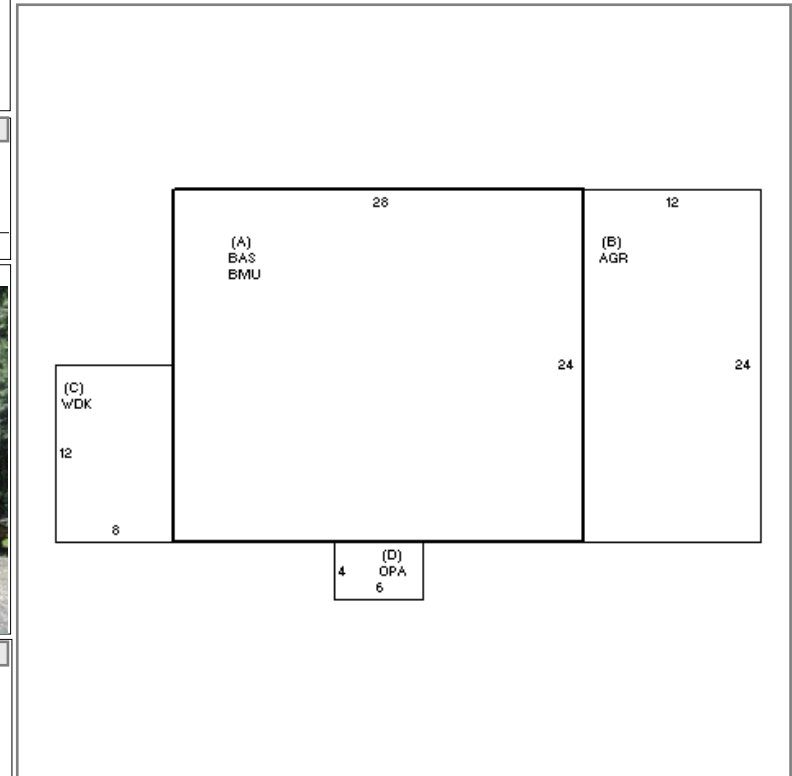

BUILDING

BUILDING	CD	ADJ	DESC	MEASURE	3/14/2022	JD
MODEL	1		RESIDENTIAL	LIST	3/14/2022	EST
STYLE	1	0.85	RANCH [100%]	REVIEW	8/8/2022	JD
QUALITY	A	1.00	AVERAGE [100%]			
FRAME	1	1.00	WOOD FRAME [100%]			

BLDG COMMENTS
ACCESSORY DWELLING
Address #69

G

YEAR BLT	2021	SIZE ADJ	1.000	ELEMENT	CD	DESCRIPTION	ADJ	S	BAT	T	DESCRIPTION	UNITS	YB	ADJ PRICE	RCN	TOTAL RCN	219,791	
NET AREA	672	DETAIL ADJ	0.875	FOUNDATION	4	CONT BSMT WALL	1.00	A	BMU	N	BSMT UNFINISHED	672		53.72	36,100	CONDITION ELEM	CD	
\$NLA(RCN)	\$327	OVERALL	1.000	EXT COVER	1	WD SHINGLES	1.00	A	BAS	L	BASE AREA	672	2021	240.52	161,631	EXTERIOR	A	
				ROOF SHAPE	1	GABLE	1.00	B	AGR	N	ATT GARAGE	288		52.22	15,038	INTERIOR	A	
				ROOF COVER	1	ASPH SHINGLES	1.00	C	WDK	N	WOOD DECK	96		38.40	3,686	KITCHEN	A	
				FLOOR COVER	12	COMB	1.00	D	OPA	N	OPEN PORCH	24		51.50	1,236	BATHS	A	
				INT FINISH	2	DRYWALL	1.00									HEAT	A	
				HEATING/COOLING	9	WARM/COOL AIR	1.03									ELECT	A	
				FUEL SOURCE	2	GAS	1.00											
CAPACITY		UNITS	ADJ															
STORIES		1	1.00															
ROOMS		4	1.00															
BEDROOMS		1	1.00															
BATHROOMS		1	1.00															
# 1/2 BATHS		0	1.00															
TOT FIXTURES		3	\$2,100															
# UNITS		1	1.00															
EFF.YR/AGE 2021 / 1																		
COND 1 1 %																		
FUNC 0																		
ECON 0																		
DEPR 1 % GD 99																		
RCNLD \$217,600																		