

Key: 2145

Town of SCITUATE - Fiscal Year 2024

10/18/2023 5:31 pm SEQ #: 2.071

LEGAL

CURRENT OWNER				PARCEL ID				LOCATION			
HEWITT B J & JOHNSON K M 631 COUNTRY WAY SCITUATE, MA 02066				20-2-11-0				631 COUNTRY WAY			
TRANSFER HISTORY				DOS	T	SALE PRICE	BK-PG (Cert)				
HEWITT B J & JOHNSON K M				05/22/1989	QS	195,000	(78601)				
NISBET JOHN E & C LEE				01/01/1973	QS		49292-				
TOLMAN PETER H AND CONSTA				01/01/1966	XX		(C00038227)				

CLASS	CLASS%	DESCRIPTION			BN ID	BN	CARD	
1010	100	SINGLE FAMILY				1	1 of 1	
PMT NO	PMT DT	TY	DESC	AMOUNT	INSP	BY	1st	%
02-346	07/01/2002	2	ADDITIONS				100	100
93-08	01/01/1993	3	ALTERATIONS				100	100
		2	ADDITIONS				100	100

LAND

CD	T	AC/SF/UN	Ngh	Infl1	Infl2	ADJ BASE	SAF	Infl3	Lpi	VC	CREDIT AMT	ADJ VALUE
100	S	39,702	NS 1.00	100	1.00	374,000	1.01	100	1.00	R02	0.85	343,020

DETACHED

TOTAL	39,702 SF	ZONING	FRNT	464	ASSESSED	CURRENT	PREVIOUS
Ngh	NO. SCITUATE	NOTE TAX MAIL.....	LAND	343,000	330,200		
Infl1	FACTOR 100		BUILDING	561,500	499,300		
Infl2	PHY 100		DETACHED	600	500		
			OTHER	0	0		
			TOTAL	905,100	830,000		

TY	QUAL	COND	DIM/NOTE	YB	UNITS	ADJ PRICE	RCNLD
S/V	A	1.00 SV 1.00	SHED		500	1.10	600

PHOTO 10/02/2003



BLDG COMMENTS

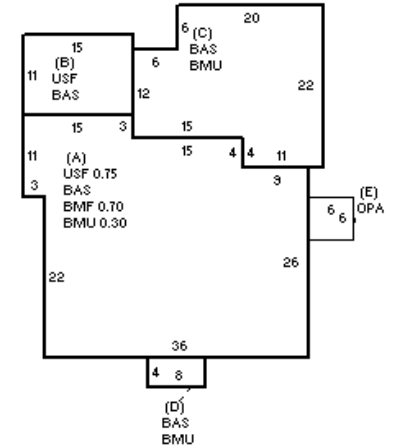

BUILDING

BUILDING	CD	ADJ	DESC	MEASURE	4/2/2009	PL
MODEL	1		RESIDENTIAL	LIST		
STYLE	4	1.10	CAPE [100%]	REVIEW	3/25/2011	KT
QUALITY	+	1.10	AVG +/GOOD - [100%]			
FRAME	1	1.00	WOOD FRAME [100%]			

LOADING

YEAR BLT	1982	SIZE ADJ	1.000	ELEMENT	CD	DESCRIPTION	ADJ	S	BAT	T	DESCRIPTION	UNITS	YB	ADJ PRICE	RCN	TOTAL RCN	729,160														
NET AREA	2,786	DETAIL ADJ	1.100	FOUNDATION	4	CONT BSMT WALL	1.00	+	BMU	N	BSMT UNFINISHED	842		46.17	38,876																
\$NLA(RCN)	\$262	OVERALL	1.000	EXT COVER	1	WD SHINGLES	1.00	A	BMF	N	BSMT FINISH-SEP	779		64.82	50,491																
				ROOF SHAPE	1	GABLE	1.00	+	USF	L	UPPER STORY FIN	1,000	1982	210.15	210,153																
				ROOF COVER	1	ASPH SHINGLES	1.00	+	BAS	L	BASE AREA	1,786	1982	231.09	412,730																
				FLOOR COVER	99	N/A	1.00	E	OPA	N	OPEN PORCH	36		56.65	2,039																
				INT FINISH	99	N/A	1.00	F21	O	O	FPL 2S 1OP	1		9,062.90	9,063																
				HEATING/COOLING	1	FORCED AIR	1.00																								
				FUEL SOURCE	99	N/A	1.00																								
				<table border="1"> <thead> <tr> <th>CONDITION ELEM</th> <th>CD</th> </tr> </thead> <tbody> <tr> <td>EXTERIOR</td> <td></td> </tr> <tr> <td>INTERIOR</td> <td></td> </tr> <tr> <td>KITCHEN</td> <td></td> </tr> <tr> <td>BATHS</td> <td></td> </tr> <tr> <td>HEAT</td> <td></td> </tr> <tr> <td>ELECT</td> <td></td> </tr> </tbody> </table>													CONDITION ELEM	CD	EXTERIOR		INTERIOR		KITCHEN		BATHS		HEAT		ELECT		
CONDITION ELEM	CD																														
EXTERIOR																															
INTERIOR																															
KITCHEN																															
BATHS																															
HEAT																															
ELECT																															
				<table border="1"> <thead> <tr> <th>EFF.YR/AGE</th> <td colspan="2">1995 / 27</td> </tr> </thead> <tbody> <tr> <td>COND</td> <td>23</td> <td>23 %</td> </tr> <tr> <td>FUNC</td> <td>0</td> <td></td> </tr> <tr> <td>ECON</td> <td>0</td> <td></td> </tr> <tr> <td>DEPR</td> <td>23</td> <td>% GD 77</td> </tr> </tbody> </table>													EFF.YR/AGE	1995 / 27		COND	23	23 %	FUNC	0		ECON	0		DEPR	23	% GD 77
EFF.YR/AGE	1995 / 27																														
COND	23	23 %																													
FUNC	0																														
ECON	0																														
DEPR	23	% GD 77																													
				<table border="1"> <thead> <tr> <th>RCNLD</th> <td>\$561,500</td> </tr> </thead> </table>													RCNLD	\$561,500													
RCNLD	\$561,500																														