

Key: 2150

Town of SCITUATE - Fiscal Year 2024

10/18/2023 5:31 pm SEQ #: 2.076

LEGAL

CURRENT OWNER				PARCEL ID				LOCATION			
LEE RICHARD A & MARGARET 14 STUDLEY ROYAL SCITUATE, MA 02066				20-3-15-0				14 STUDLEY ROYAL			
TRANSFER HISTORY				DOS	T	SALE PRICE	BK-PG (Cert)				
LEE RICHARD A & MARGARET				07/28/2015	F	100 (119261)					
LEE RICHARD A & MARGARET				07/11/2013	F	100 (119261)					
LEE RICHARD A & MARGARET				07/11/2013	F	100 43329-74					

CLASS	CLASS%	DESCRIPTION			BN ID	BN	CARD	
1010	100	SINGLE FAMILY				1	1 of 1	
PMT NO	PMT DT	TY	DESC	AMOUNT	INSP	BY	1st	%
13-638	09/19/2013	3	ALTERATIONS	69,182	06/24/2014	MR	100	100
98-67	03/05/1998	3	ALTERATIONS				100	100

LAND

CD	T	AC/SF/UN	Ngh	Inf1	Inf2	ADJ BASE	SAF	Inf3	Lpi	VC	CREDIT AMT	ADJ VALUE
100	S	17,150	NS 1.00	100 1.00	100 1.00	374,000	2.16	100 1.00	R03	0.85		317,440

TOTAL	17,150 SF	ZONING	NO. SCITUATE	FRNT	101	ASSESSED	CURRENT	PREVIOUS
Ngh	NO. SCITUATE	NOTE		LAND	317,400	305,600		
Inf1	FACTOR 100		BUILDING	538,300	478,800			
Inf2	PHY 100		DETACHED	12,100	11,000			
			OTHER	0	0			
				TOTAL	867,800	795,400		

DETACHED

TY	QUAL	COND	DIM/NOTE	YB	UNITS	ADJ PRICE	RCNLD
S/V	A	1.00	SV 1.00 LUMBER SHOP		6,200	1.10	6,800
S/V	A	1.00	SV 1.00 STORAGE		4,800	1.10	5,300

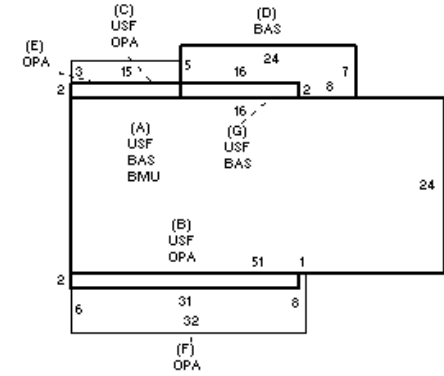

BUILDING

BUILDING	CD	ADJ	DESC	MEASURE	6/24/2014	MR
MODEL	1		RESIDENTIAL	LIST		
STYLE	7	1.20	CONVENTIONAL [100%]	REVIEW	7/3/2014	TD
QUALITY	+	1.10	AVG +/GOOD - [100%]			
FRAME	1	1.00	WOOD FRAME [100%]			

BLDG COMMENTS
FY12 FR-COLONIAL TO CONV

G

YEAR BLT	1905	SIZE ADJ	1.000	ELEMENT	CD	DESCRIPTION	ADJ	S	BAT	T	DESCRIPTION	UNITS	YB	ADJ PRICE	RCN	TOTAL RCN	769,067				
NET AREA	2,740	DETAIL ADJ	1.224	FOUNDATION	4	CONT BSMT WALL	1.00	A	BMU	N	BSMT UNFINISHED	1,224		49.14	60,141	CONDITION ELEM	CD				
\$NLA(RCN)	\$281	OVERALL	1.000	EXT COVER	4	VINYL	1.00	+	USF	L	UPPER STORY FIN	1,348	1905	234.36	315,917	EXTERIOR	V				
				ROOF SHAPE	1	GABLE	1.00	+	OPA	N	OPEN PORCH	331		56.65	18,752	INTERIOR	A				
				ROOF COVER	1	ASPH SHINGLES	1.00	+	BAS	L	BASE AREA	1,392	1905	257.71	358,732	KITCHEN	A				
				FLOOR COVER	99	N/A	1.00		F21	O	FPL 2S 1OP	1		9,062.90	9,063	BATHS	A				
				INT FINISH	99	N/A	1.00		GEN	O	GENERATOR	1		0.00		HEAT	A				
				HEATING/COOLING	2	HOT WATER	1.02									ELECT	A				
				FUEL SOURCE	99	N/A	1.00														
CAPACITY		UNITS	ADJ															EFF.YR/AGE	1973 / 49		
STORIES	2	1.00																COND	30 30%		
ROOMS	10	1.00																FUNC	0		
BEDROOMS	4	1.00																ECON	0		
BATHROOMS	2	1.00																DEPR	30	% GD	70
# 1/2 BATHS	0	1.00																RCNLD	\$538,300		
TOT FIXTURES	6	\$6,463																			
# UNITS	1	1.00																			