

Key: 2176

Town of SCITUATE - Fiscal Year 2024

10/18/2023 5:31 pm SEQ #: 2.102

LEGAL

LAND

DETACHED

BUILDING

CURRENT OWNER				PARCEL ID				LOCATION			
KINSLEY JOHN & BETH 8 PRATT RD SCITUATE, MA 02066				26-6-1-0				8 PRATT RD			
TRANSFER HISTORY				DOS	T	SALE PRICE	BK-PG (Cert)				
KINSLEY JOHN & BETH				08/17/2005	QS	867,575	31157-129				
MCLAUGHLIN BRIAN TRS				01/15/2004	F	-100	27389-152				
MCLAUGHLIN BRIAN				12/31/2003	A	217,977	27320-225				

CLASS	CLASS%	DESCRIPTION			BN ID	BN	CARD	
1010	100	SINGLE FAMILY				1	1 of 1	
PMT NO	PMT DT	TY	DESC	AMOUNT	INSP	BY	1st	%
03-520	08/29/2003	3	ALTERATIONS		06/25/2009	SJ	100	100
		1	NEW CONST		06/21/2006	SJ	100	100
		1	NEW CONST		05/31/2005	SJ	100	100
		1	NEW CONST	310,000	08/02/2004	SJ	100	100

CD	T	AC/SF/UN	Ngh	Inf1	Inf2	ADJ BASE	SAF	Inf3	Lpi	VC	CREDIT AMT	ADJ VALUE
100	S	21,244	NS	1.00	1.00	440,000	1.77	1.00	R04	1.00		379,540

TOTAL	21,257 SF	ZONING	IN M20...	FRNT	240	ASSESSED	CURRENT	PREVIOUS
Ngh	NO. SCITUATE	NOTE		LAND		379,500	345,000	
Inf1	FACTOR 100		BUILDING		909,100	793,300		
Inf2	PHY 100		DETACHED		0	0		
			OTHER		0	0		
				TOTAL		1,288,600	1,138,300	

TY	QUAL	COND	DIM/NOTE	YB	UNITS	ADJ PRICE	RCNLD



BLDG COMMENTS
OTHER FIX=SHOWER
FY12 QUALITY CHANGE FROM VGD TO GD, STYLE CHANGE FROM CONV TO COL PER FIELD REVIEW.

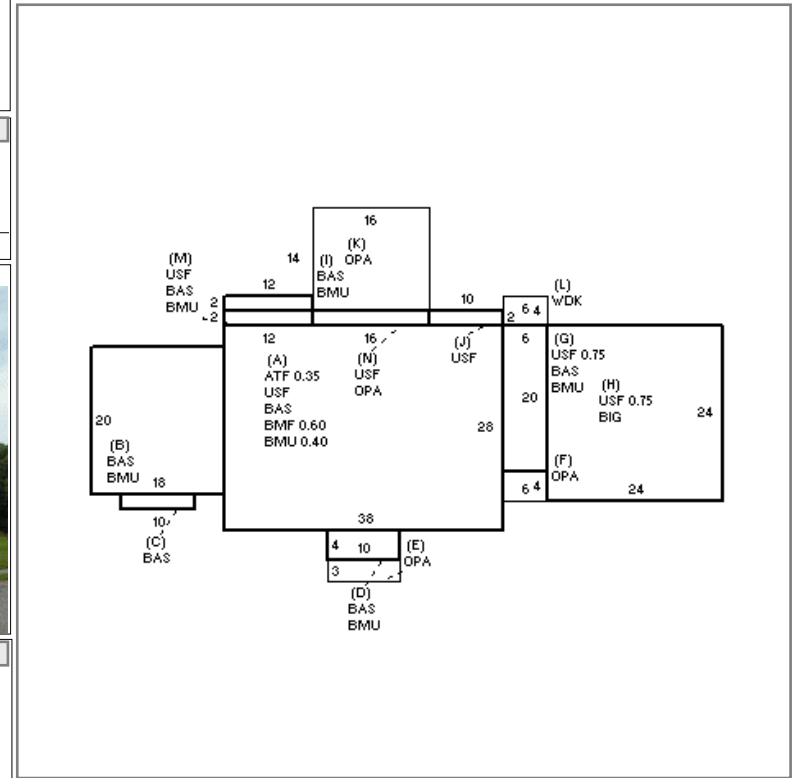

BUILDING	CD	ADJ	DESC	MEASURE	3/6/2013	SJ
MODEL	1		RESIDENTIAL	LIST	3/6/2013	EST
STYLE	5	1.00	COLONIAL [100%]	REVIEW	3/28/2011	KT
QUALITY	V	1.40	VERY GOOD [100%]			
FRAME	1	1.00	WOOD FRAME [100%]			

YEAR BLT	2004	SIZE ADJ	1.000	ELEMENT	CD	DESCRIPTION	ADJ	S	BAT	T	DESCRIPTION	UNITS	YB	ADJ PRICE	RCN	TOTAL RCN	1,108,618			
NET AREA	3,686	DETAIL ADJ	1.040	FOUNDATION	4	CONT BSMT WALL	1.00	+	BMU	N	BSMT UNFINISHED	994		58.70	58,352	CONDITION ELEM	CD			
\$NLA(RCN)	\$301	OVERALL	1.000	EXT COVER	2	CLAPBOARD	1.00	A	BMF	N	BSMT FINISH-SEP	638		82.41	52,577	EXTERIOR				
				ROOF SHAPE	1	GABLE	1.00	A	ATF	L	ATTIC FINISH	372	2004	173.52	64,548	INTERIOR				
				ROOF COVER	1	ASPH SHINGLES	1.00	+	BAS	L	BASE AREA	1,652	2004	268.56	443,660	KITCHEN				
				FLOOR COVER	99	N/A	1.00	+	OPA	N	OPEN PORCH	310		72.10	22,351	BATHS				
				INT FINISH	99	N/A	1.00	H	BIG	N	BUILT-IN GARAGE	576		62.09	35,764	HEAT				
				HEATING/COOLING	11	HW/COOL AIR	1.04	+	USF	L	UPPER STORY FIN	1,662	2004	244.23	405,903	ELECT				
				FUEL SOURCE	99	N/A	1.00	L	WDK	N	WOOD DECK	24		53.78	1,291					
									F11	O	FPL 1S 1OP	1		10,193.40	10,193					
CAPACITY		UNITS	ADJ															EFF.YR/AGE	2004 / 18	
STORIES		2.5	1.00															COND	17 17 %	
ROOMS		9	1.00															FUNC	0	
BEDROOMS		4	1.00															ECON	0	
BATHROOMS		3	1.00															DEPR	18 % GD	82
# 1/2 BATHS		1	1.00															RCNLD	\$909,100	
TOT FIXTURES		12	\$13,978																	
# UNITS		1	1.00																	