

Key: 2254

Town of SCITUATE - Fiscal Year 2024

10/18/2023 5:31 pm SEQ #: 2.172

LEGAL

LAND

Table with columns: CURRENT OWNER, PARCEL ID, LOCATION, TRANSFER HISTORY, DOS, T, SALE PRICE, BK-PG (Cert). Includes owner name JOHNSTON TRACY E TR & WILLIAM C TR and parcel details.

Table with columns: CLASS, CLASS%, DESCRIPTION, BN ID, BN, CARD. Includes details for 1010 SINGLE FAMILY class and various PMT NO, PMT DT, TY, DESC, AMOUNT, INSP, BY, 1st, %.

Table with columns: CD, T, AC/SF/UN, Ngh, Infl1, Infl2, ADJ BASE, SAF, Infl3, Lpi, VC, CREDIT AMT, ADJ VALUE. Includes totals for 2.180 Acres and assessed values.

Table with columns: TY, QUAL, COND, DIM/NOTE, YB, UNITS, ADJ PRICE, RCNLD. Includes rows for IPG, PLH, OPA with various quality and condition metrics.

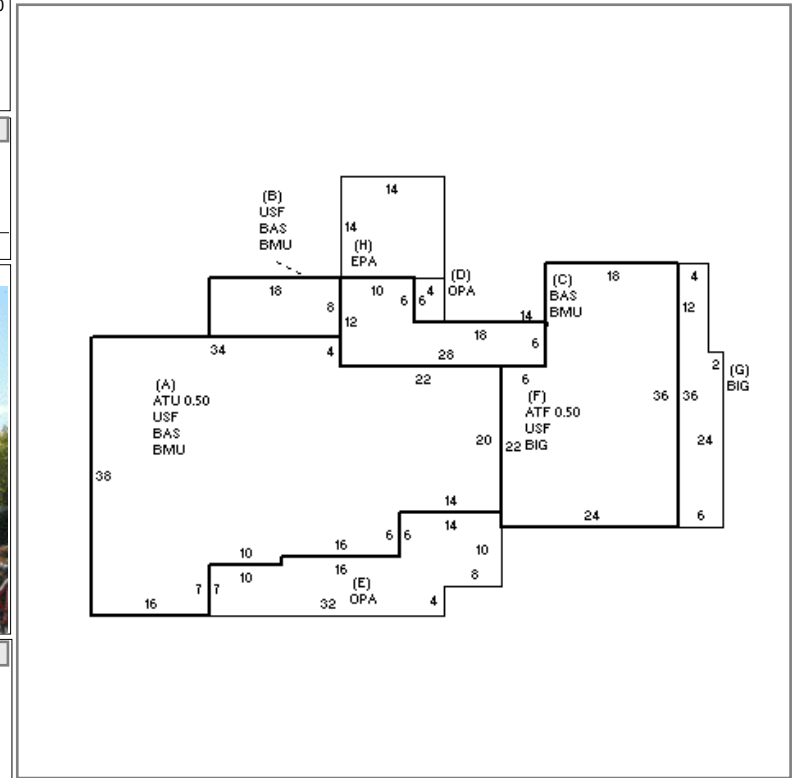

Table with columns: BUILDING, CD, ADJ, DESC, MEASURE, 8/7/2013, MR, LIST, 8/7/2013, EST, REVIEW, 7/15/2014, TD. Includes building details like RESIDENTIAL COLONIAL [100%].

BLDG COMMENTS: 1/2 BATH & BAR W/AC IN POOLHOUSE

DETACHED

BUILDING

Large summary table with columns: YEAR BLT, NET AREA, \$NLA(RCN), CAPACITY, UNITS, ADJ, ELEMENT, CD, DESCRIPTION, ADJ, S, BAT, T, DESCRIPTION, UNITS, YB, ADJ PRICE, RCN, TOTAL RCN, 1,272,355, CONDITION ELEM, CD, EFF.YR/AGE, 2004 / 18, COND, 17 17%, FUNC, 0, ECON, 0, DEPR, 18 % GD, 82, RCNLD, \$1,043,300.