

Key: 2262

Town of SCITUATE - Fiscal Year 2024

10/18/2023 5:31 pm SEQ #: 2.180

LEGAL

CURRENT OWNER				PARCEL ID				LOCATION			
CORBETT LEO M & DIANE 48 SEDGEWICK DRIVE NORTH SCITUATE, MA 02066				21-6-1-0				48 SEDGEWICK DR			
TRANSFER HISTORY				DOS	T	SALE PRICE	BK-PG (Cert)				
CORBETT LEO M & DIANE				12/31/1993	QS	250,000	12552-36				
WOOD OLIVER G & MURIEL				01/01/1967	XX		3274-135				
FALVEY FRANK B AND ANN P				01/01/1962	XX		2904-18				

CLASS	CLASS%	DESCRIPTION			BN ID	BN	CARD
1010	100	SINGLE FAMILY				1	1 of 1
PMT NO	PMT DT	TY	DESC	AMOUNT	INSP	BY	1st %
04-262	05/07/2004	3	ALTERATIONS				100 100

LAND

CD	T	AC/SF/UN	Ngh	Inf1	Inf2	ADJ BASE	SAF	Inf3	Lpi	VC	CREDIT AMT	ADJ VALUE	
100	S	20,959	NS 1.00	100	1.00	100	1.00	594,000	1.79	90	0.90	WV2 1.50	511,820

TOTAL	20,952 SF	ZONING	NO. SCITUATE	FRNT	123	ASSESSED	511,800	CURRENT	465,300	PREVIOUS	400,800
Ngh	NO. SCITUATE	NOTE		LAND			426,800		0		0
Inf1	FACTOR 100			BUILDING			0		0		0
Inf2	PHY 100			DETACHED			0		0		0
				OTHER					0		0
				TOTAL			938,600		866,100		

DETACHED

TY	QUAL	COND	DIM/NOTE	YB	UNITS	ADJ PRICE	RCNLD



BLDG COMMENTS

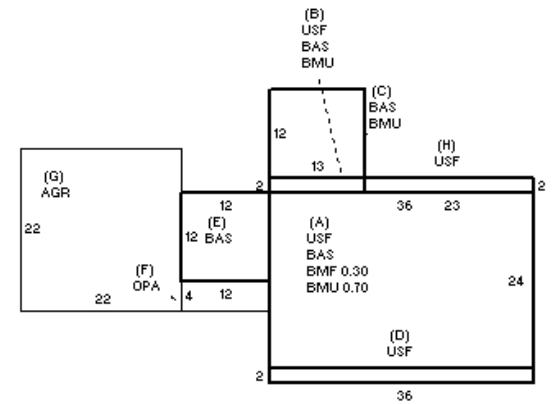

BUILDING

BUILDING	CD	ADJ	DESC	MEASURE	3/12/2012	PL
MODEL	1		RESIDENTIAL	LIST	3/12/2012	EST
STYLE	5	1.00	COLONIAL [100%]	REVIEW	3/28/2011	KT
QUALITY	+	1.10	AVG +/GOOD - [100%]			
FRAME	1	1.00	WOOD FRAME [100%]			

YEAR BLT	1961	SIZE ADJ	1.000	ELEMENT	CD	DESCRIPTION	ADJ
NET AREA	2,198	DETAIL ADJ	1.020	FOUNDATION	4	CONT BSMT WALL	1.00
\$NLA(RCN)	\$259	OVERALL	1.000	EXT COVER	2	CLAPBOARD	1.00
CAPACITY				UNITS	ADJ		
STORIES	2	1.00		ROOF SHAPE	1	GABLE	1.00
ROOMS	9	1.00		ROOF COVER	1	ASPH SHINGLES	1.00
BEDROOMS	4	1.00		FLOOR COVER	99	N/A	1.00
BATHROOMS	1	1.00		INT FINISH	99	N/A	1.00
# 1/2 BATHS	2	1.00		HEATING/COOLING	2	HOT WATER	1.02
TOT FIXTURES	7	\$6,283		FUEL SOURCE	99	N/A	1.00
# UNITS	1	1.00					

S	BAT	T	DESCRIPTION	UNITS	YB	ADJ PRICE	RCN
+	BMU	N	BSMT UNFINISHED	787		51.22	40,310
A	BMF	N	BSMT FINISH-SEP	259		71.90	18,622
+	USF	L	UPPER STORY FIN	1,008	1961	202.18	203,799
+	BAS	L	BASE AREA	1,190	1961	222.33	264,569
F	OPA	N	OPEN PORCH	48		56.65	2,719
G	AGR	N	ATT GARAGE	484		48.90	23,667
	F21	O	FPL 2S 1OP	1		9,062.90	9,063

TOTAL RCN	569,031
CONDITION ELEM	CD
EXTERIOR	
INTERIOR	
KITCHEN	
BATHS	
HEAT	
ELECT	
EFF.YR/AGE	1990 / 32
COND	25 25%
FUNC	0
ECON	0
DEPR	25 % GD 75
RCNLD	\$426,800