

Key: 2292

Town of SCITUATE - Fiscal Year 2024

10/18/2023 5:31 pm SEQ #: 2.203

LEGAL

LAND

CURRENT OWNER				PARCEL ID				LOCATION			
COSTELLO LEO TR 3 LONGMEADOW RD SCITUATE, MA 02066				27-6-55-0				3 LONGMEADOW RD			
TRANSFER HISTORY				DOS	T	SALE PRICE	BK-PG (Cert)				
COSTELLO LEO TR				06/15/2018	F	100	49920-341				
COSTELLO TYLER B TR				06/15/2018	F	100	49921-1				
COSTELLO LEO C JR TR				07/22/2015	F	100	45828-115				

CLASS	CLASS%	DESCRIPTION			BN ID	BN	CARD	
1010	100	SINGLE FAMILY				1	1 of 1	
PMT NO	PMT DT	TY	DESC	AMOUNT	INSP	BY	1st	%
18-403	06/21/2018	1	NEW CONST	500,000	07/12/2018	JD	100	0
18-403	06/21/2018	1	NEW CONST	500,000	04/17/2019	JD	100	70
18-403	06/21/2018	1	NEW CONST	500,000	05/27/2020	JD	100	100
62-352	06/01/2018	5	SPLIT/SUB/LA		04/17/2019	JD	100	100

CD	T	AC/SF/UN	Ngh	Infl1	Infl2	ADJ BASE	SAF	Infl3	Lpi	VC	CREDIT AMT	ADJ VALUE
100	S	40,000	NS 1.00	100	1.00	440,000	1.00	100	1.00	R04	1.00	404,040
300	A	4,990	NS 1.00	100	1.00	13,860	1.00	70	0.70	R04	1.00	69,160

TOTAL	5.908 Acres	ZONING	FRNT	273	ASSESSED	CURRENT	PREVIOUS
Ngh	NO. SCITUATE	NOTE			LAND	473,200	433,700
Infl1	FACTOR 100		BUILDING	1,163,400	1,008,800		
Infl2	PHY 100		DETACHED	0	0		
			OTHER	0	0		
			TOTAL		1,636,600	1,442,500	

TY	QUAL	COND	DIM/NOTE	YB	UNITS	ADJ PRICE	RCNLD	PHOTO	05/27/2020
									

BUILDING	CD	ADJ	DESC	MEASURE	4/17/2019	JD
MODEL	1		RESIDENTIAL	LIST	4/17/2019	JD
STYLE	5	1.00	COLONIAL [100%]	REVIEW	5/27/2020	JD
QUALITY	V	1.40	VERY GOOD [100%]			
FRAME	1	1.00	WOOD FRAME [100%]			

YEAR BLT	2019	SIZE ADJ	1.000	ELEMENT	CD	DESCRIPTION	ADJ	S	BAT	T	DESCRIPTION	UNITS	YB	ADJ PRICE	RCN	TOTAL RCN	1,199,400
NET AREA	3,604	DETAIL ADJ	1.030	FOUNDATION	4	CONT BSMT WALL	1.00	A	AGR	N	ATT GARAGE	852		53.28	45,396		
\$NLA(RCN)	\$333	OVERALL	1.000	EXT COVER	1	WD SHINGLES	1.00	B	BIG	N	BUILT-IN GARAGE	256		54.88	14,049		
				ROOF SHAPE	2	HIP	1.00	+	BAS	L	BASE AREA	2,032	2019	266.89	542,318		
				ROOF COVER	1	ASPH SHINGLES	1.00	+	BMU	N	BSMT UNFINISHED	1,092		57.76	63,076		
				FLOOR COVER	12	COMB	1.00	C	BMF	N	BSMT FINISH-SEP	684		81.09	55,462		
				INT FINISH	2	DRYWALL	1.00	C	USF	L	UPPER STORY FIN	1,368	2019	242.71	332,023		
				HEATING/COOLING	9	WARM/COOL AIR	1.03	D	ATF	L	ATTIC FINISH	204	2019	172.44	35,178		
				FUEL SOURCE	2	GAS	1.00	+	OPA	N	OPEN PORCH	1,184		72.10	85,366		
									F21	O	FPL 2S 1OP	1		11,534.60	11,535		
									GEN	O	GENERATOR	1		0.00			

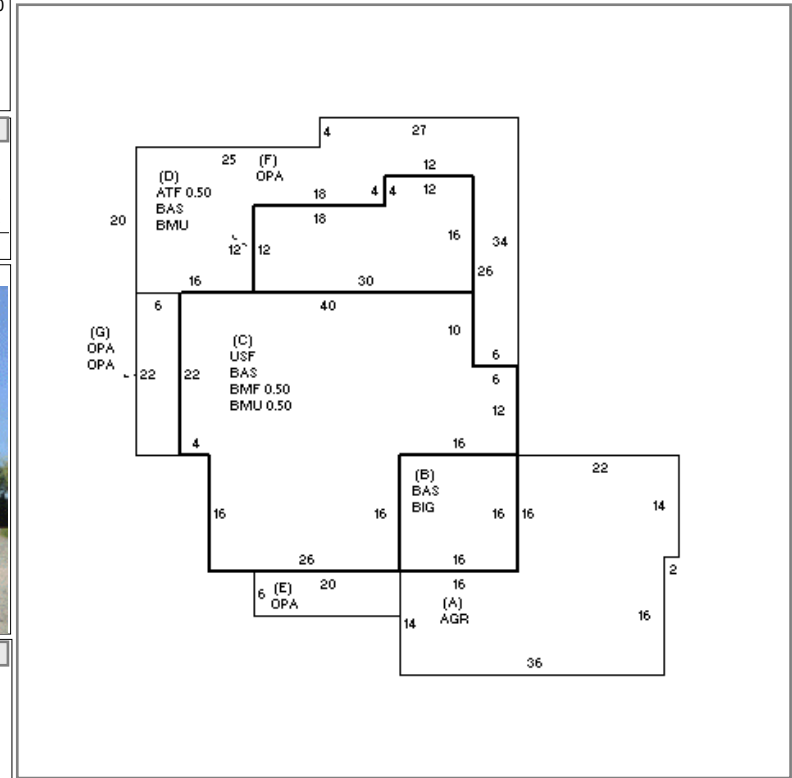

DETACHED

BUILDING

INDIN

G

CONDITION ELEM	CD
EXTERIOR	A
INTERIOR	A
KITCHEN	A
BATHS	A
HEAT	A
ELECT	A

EFF.YR/AGE	2019 / 3
COND	3 3 %
FUNC	0
ECON	0
DEPR	3 % GD 97

RCNLD	\$1,163,400
-------	-------------