

Key: 2377

Town of SCITUATE - Fiscal Year 2024

10/18/2023 5:31 pm SEQ #: 2.289

LEGAL

CURRENT OWNER										PARCEL ID				LOCATION			
THE 453 TILDEN RD REALTY TR 453 TILDEN RD SCITUATE, MA 02066										27-1-14-0				453 TILDEN RD			
TRANSFER HISTORY										DOS	T	SALE PRICE		BK-PG (Cert)			
THE 453 TILDEN RD REALTY										06/09/2017	F	1 48526-267					
SCIUCCO KRISTIN M										09/11/2015	QS	840,000 46030-263					
BUCKLEY JONATHAN										08/26/2015	F	100 45969-201					

CLASS	CLASS%	DESCRIPTION			BN ID	BN	CARD	
1010	100	SINGLE FAMILY				1	1 of 1	
PMT NO	PMT DT	TY	DESC	AMOUNT	INSP	BY	1st	%
13-074	02/19/2013	2	ADDITIONS	9,500	07/01/2013	SJ	100	100
06-295	05/22/2006	3	ALTERATIONS	4,468	06/22/2006	SJ	100	100
05-197	05/02/2005	3	ALTERATIONS	1,000	08/16/2005	SJ	100	100
01-046	02/06/2001	3	ALTERATIONS				100	100
97-648	11/17/1997	1	NEW CONST				100	100

LAND

CD	T	AC/SF/UN	Ngh	Inf1	Inf2	ADJ BASE	SAF	Inf3	Lpi	VC	CREDIT AMT	ADJ VALUE
100	S	40,000 SC	1.00	100	100	396,000	1.00	100	1.00	R02	0.90	363,640
300	A	0.019 SC	1.00	100	100	17,820	1.00	100	1.00	R02	0.90	340

DETACHED

TOTAL	40,859 SF	ZONING	FRNT	216	ASSESSED	CURRENT	PREVIOUS
Ngh	SCITUATE	N O T E			LAND	364,000	349,300
Inf1	FACTOR 100				BUILDING	750,200	667,300
Inf2	PHY 100				DETACHED	12,300	11,200
						OTHER	0
						TOTAL	1,126,500
							1,027,800

TY	QUAL	COND	DIM/NOTE	YB	UNITS	ADJ PRICE	RCNLD
S/V	A	1.00	SV 1.00 SHED		200	1.10	200
S/V	A	1.00	SV 1.00 GUNITE/STEEL	1972	11,000	1.10	12,100



BUILDING	CD	ADJ	DESC	MEASURE	4/10/2009	PL
MODEL	1		RESIDENTIAL	LIST		
STYLE	7	1.20	CONVENTIONAL [100%]	REVIEW	3/29/2011	KT
QUALITY	G	1.20	GOOD [100%]			
FRAME	1	1.00	WOOD FRAME [100%]			

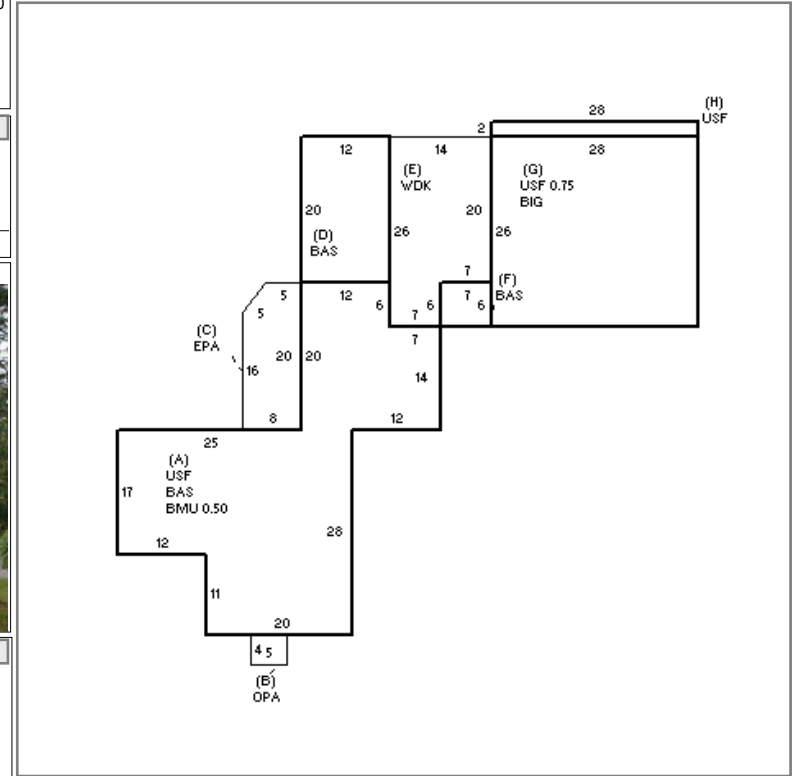

BUILDING

YEAR BLT	1902	SIZE ADJ	1.000	ELEMENT	CD	DESCRIPTION	ADJ	S	BAT	T	DESCRIPTION	UNITS	YB	ADJ PRICE	RCN	TOTAL RCN	949,660				
NET AREA	3,088	DETAIL ADJ	1.224	FOUNDATION	5	BRICK/STONE	1.00	A	BMU	N	BSMT UNFINISHED	551		69.77	38,442	CONDITION ELEM	CD				
\$NLA(RCN)	\$308	OVERALL	1.000	EXT COVER	2	CLAPBOARD	1.00	B	OPA	N	OPEN PORCH	20		61.80	1,236	EXTERIOR					
				ROOF SHAPE	1	GABLE	1.00	C	EPA	N	ENCLOSED PORCH	154		108.24	16,669	INTERIOR					
				ROOF COVER	1	ASPH SHINGLES	1.00	+	BAS	L	BASE AREA	1,384	1902	276.80	383,095	KITCHEN					
				FLOOR COVER	99	N/A	1.00	E	WDK	N	WOOD DECK	322		46.08	14,838	BATHS					
				INT FINISH	99	N/A	1.00	G	BIG	N	BUILT-IN GARAGE	728		59.72	43,477	HEAT					
				HEATING/COOLING	2	HOT WATER	1.02	+	USF	L	UPPER STORY FIN	1,704	1902	251.72	428,935	ELECT					
				FUEL SOURCE	2	GAS	1.00	F22	O		FPL 2S 2OP	1		13,566.00	13,566						
																		EFF.YR/AGE	2000 / 22		
																		COND	20 20 %		
																		FUNC	0		
																		ECON	0		
																		DEPR	21	% GD	79
																		RCNLD	\$750,200		