

Key: 2389

Town of SCITUATE - Fiscal Year 2024

10/18/2023 5:31 pm SEQ #: 2.301

LEG
A
L

CURRENT OWNER				PARCEL ID				LOCATION			
HOLLENBACK MATTHIAS L & AMANDA P 24 ROSA'S LN SCITUATE, MA 02066				27-1-19-J				24 ROSA'S LN			
TRANSFER HISTORY				DOS	T	SALE PRICE	BK-PG (Cert)				
HOLLENBACK MATTHIAS L & WLODYKA THOMAS H & HELEN				06/18/2020	QS	635,000	52929-176				
MCVEIGH THOMAS A AND EILE				11/19/1982	QS	86,000	5246-438				
				01/01/1969	XX		3431-634				

CLASS	CLASS%	DESCRIPTION			BN ID	BN	CARD
1010	100	SINGLE FAMILY				1	1 of 1
PMT NO	PMT DT	TY	DESC	AMOUNT	INSP	BY	1st %

L
A
N
D

CD	T	AC/SF/UN	Ngh	Inf1	Inf2	ADJ BASE	SAF	Inf3	Lpi	VC	CREDIT AMT	ADJ VALUE
100	S	20,221	SC 1.00	100	1.00	396,000	1.85	100	1.00	R04	0.90	340,250

D
E
T
A
C
H
E
D

TOTAL	20,221 SF	ZONING	FRNT	126	ASSESSED	CURRENT	PREVIOUS
Ngh	SCITUATE	N O T E			LAND	340,300	326,500
Inf1	FACTOR 100		BUILDING	407,900	367,700		
Inf2	PHY 100		DETACHED	1,700	1,600		
			OTHER	0	0		
			TOTAL	749,900	695,800		

TY	QUAL	COND	DIM/NOTE	YB	UNITS	ADJ PRICE	RCNLD
SHF	A	1.00	30 0.70 20X10		200	12.29	1,700

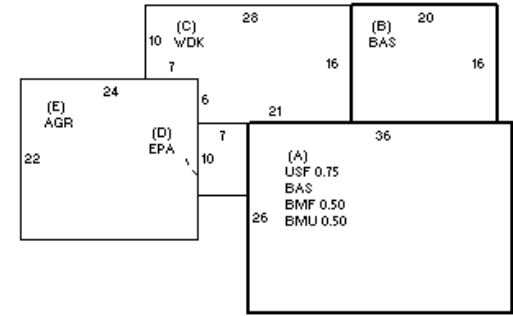

B
U
I
L
D
I
N
G

BUILDING	CD	ADJ	DESC	MEASURE	7/8/2021	JD
MODEL	1		RESIDENTIAL	LIST	7/13/2021	EST
STYLE	4	1.10	CAPE [100%]	REVIEW	9/24/2020	JD
QUALITY	A	1.00	AVERAGE [100%]			
FRAME	1	1.00	WOOD FRAME [100%]			

BLDG COMMENTS		
MLS		

YEAR BLT	1962	SIZE ADJ	1.000	ELEMENT	CD	DESCRIPTION	ADJ	S	BAT	T	DESCRIPTION	UNITS	YB	ADJ PRICE	RCN	TOTAL RCN	551,272		
NET AREA	1,958	DETAIL ADJ	1.144	FOUNDATION	4	CONT BSMT WALL	1.00	A	BMU	N	BSMT UNFINISHED	468		48.08	22,501	CONDITION ELEM	CD		
\$NLA(RCN)	\$282	OVERALL	1.000	EXT COVER	1	WD SHINGLES	1.00	A	BMF	N	BSMT FINISH-SEP	468		67.49	31,586	EXTERIOR	A		
				ROOF SHAPE	1	GABLE	1.00	A	USF	L	UPPER STORY FIN	702	1962	210.53	147,794	INTERIOR	G		
				ROOF COVER	1	ASPH SHINGLES	1.00	+	BAS	L	BASE AREA	1,256	1962	231.51	290,775	KITCHEN	A		
				FLOOR COVER	24	COMB	1.00	C	WDK	N	WOOD DECK	406		38.40	15,590	BATHS	A		
				INT FINISH	1	PLASTER	1.00	D	EPA	N	ENCLOSED PORCH	70		90.20	6,314	HEAT	U		
				HEATING/COOLING	11	HW/COOL AIR	1.04	E	AGR	N	ATT GARAGE	528		43.53	22,982	ELECT	U		
				FUEL SOURCE	1	OIL	1.00	F21	O	O	FPL 2S 1OP	1		8,239.00	8,239				
																		EFF.YR/AGE	1984 / 38
																		COND	26 26 %
																		FUNC	0
																		ECON	0
																		DEPR	26 % GD 74
																		RCNLD	\$407,900