

Key: 2543

Town of SCITUATE - Fiscal Year 2024

10/18/2023 5:31 pm SEQ #: 2.449

LEGAL

CURRENT OWNER				PARCEL ID				LOCATION			
CANALE ARNOLD F & MARIE TRS 57 BARBARA LANE MILTON, MA 02186				5-4-17-0				96 GLADES RD			
TRANSFER HISTORY				DOS	T	SALE PRICE	BK-PG (Cert)				
CANALE ARNOLD F & MARIE T				11/14/1997	F	1	15646-300				
CANALE ARNOLD F & MARIE P				08/21/1985	QS	200,000	6264-154				
MINOT LIGHT INN INC				01/01/1965	XX		3090-350				

CLASS	CLASS%	DESCRIPTION			BN ID	BN	CARD	
1050	100	THREE FAMILY				1	1 of 1	
PMT NO	PMT DT	TY	DESC	AMOUNT	INSP	BY	1st	%
92-472	06/08/1992	7	OTHERS		10/31/2022	JD	100	100
		3	ALTERATIONS	1,000			100	100
		6	CYCL GROWTH				100	100

LAND

CD	T	AC/SF/UN	Ngh	Inf1	Inf2	ADJ BASE	SAF	Inf3	Lpi	VC	CREDIT AMT	ADJ VALUE
100	S	12,730 MB	1.00	100	1.00	1,100,000	2.85	100	1.00	WF2	2.50	915,560

TOTAL	12,730 SF	ZONING	N O T E	FRNT	101	ASSESSED	915,600	CURRENT	420,200	PREVIOUS	832,300
Ngh	MINOT BCH					LAND	420,200				210,200
Inf1	FACTOR 100					BUILDING	0				0
Inf2	PHY 100					DETACHED	0				0
						OTHER	0				0
						TOTAL	1,335,800				1,042,500

DETACHED

TY	QUAL	COND	DIM/NOTE	YB	UNITS	ADJ PRICE	RCNLD

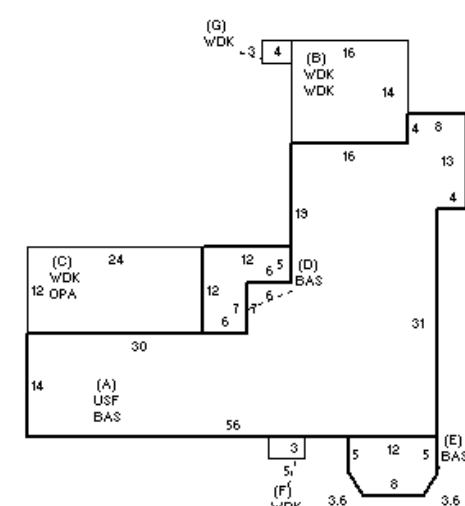

BLDG COMMENTS		

BUILDING

BUILDING	CD	ADJ	DESC	MEASURE	10/31/2022	JD
MODEL	1		RESIDENTIAL	LIST	10/31/2022	EST
STYLE	7	1.20	CONVENTIONAL [100%]	REVIEW	3/30/2011	KT
QUALITY	A	1.00	AVERAGE [100%]			
FRAME	1	1.00	WOOD FRAME [100%]			

YEAR BLT	1900	SIZE ADJ	1.000
NET AREA	3,020	DETAIL ADJ	1.260
\$NLA(RCN)	\$248	OVERALL	1.000
CAPACITY		UNITS	ADJ
STORIES	2	1.00	
ROOMS	12	1.00	
BEDROOMS	5	1.00	
BATHROOMS	3	1.00	
# 1/2 BATHS	0	1.00	
TOT FIXTURES	9	\$9,072	
# UNITS	3	1.03	

ELEMENT	CD	DESCRIPTION	ADJ	S	BAT	T	DESCRIPTION	UNITS	YB	ADJ PRICE	RCN
FOUNDATION	5	BRICK/STONE	1.00	+	BAS	L	BASE AREA	1,606	1900	238.25	382,630
EXT COVER	1	WD SHINGLES	1.00	A	USF	L	UPPER STORY FIN	1,414	1900	216.66	306,362
ROOF SHAPE	1	GABLE	1.00	+	WDK	N	WOOD DECK	763		38.40	29,299
ROOF COVER	1	ASPH SHINGLES	1.00	C	OPA	N	OPEN PORCH	288		51.50	14,832
FLOOR COVER	24	COMB	1.00	F21	O	O	FPL 2S 1OP	1		8,239.00	8,239
INT FINISH	1	PLASTER	1.00								
HEATING/COOLING	2	HOT WATER	1.02								
FUEL SOURCE	2	GAS	1.00								

TOTAL RCN	750,434
CONDITION ELEM	CD
EXTERIOR	F
INTERIOR	F
KITCHEN	F
BATHS	F
HEAT	A
ELECT	A
EFF.YR/AGE	1963 / 59
COND	44 44 %
FUNC	0
ECON	0
DEPR	44 % GD 56
RCNLD	\$420,200