

Key: 2596

Town of SCITUATE - Fiscal Year 2024

10/18/2023 5:31 pm SEQ #: 2.503

LEGAL

LAND

DETACHED

BUILDING

CURRENT OWNER				PARCEL ID				LOCATION			
BARRY MAUREEN 58 GANNETT ROAD SCITUATE, MA 02066				7-5-36-0				58 GANNETT RD			
TRANSFER HISTORY				DOS	T	SALE PRICE	BK-PG (Cert)				
BARRY MAUREEN				04/10/2001	F		19643-53				
CHASON MARK L & BARRY MAU				12/21/1987	QS	300,000	8197-316				
MORTON ROGER				01/01/1985	QS	178,500	6265-116				

CLASS	CLASS%	DESCRIPTION		BN ID	BN	CARD	
1040	100	TWO FAMILY			1	1 of 1	
PMT NO	PMT DT	TY	DESC	AMOUNT	INSP	BY	1st %
08-100	03/01/2008	7	OTHERS		11/02/2022	JD	100 100
00-402	08/24/2000	3	ALTERATIONS	3,000	05/14/2008	SJ	100 100
99-106	03/31/1999	2	ADDITIONS				100 100
		3	ALTERATIONS				100 100
		7	OTHERS				100 100

CD	T	AC/SF/UN	Ngh	Inf1	Inf2	ADJ BASE	SAF	Inf3	Lpi	VC	CREDIT AMT	ADJ VALUE
100	S	24,156	NS	1.00	100	1.00	100	1.00	R02	0.85		326,070

TOTAL	24,156 SF	ZONING	NO. SCITUATE	FRNT	348	ASSESSED	326,100	CURRENT	311,700	PREVIOUS	313,900
Ngh	NO. SCITUATE	NOTE	LAND								243,600
Inf1	FACTOR 100		BUILDING								5,100
Inf2	PHY 100		DETACHED								0
			OTHER								0
			TOTAL				637,800				562,600

TY	QUAL	COND	DIM/NOTE	YB	UNITS	ADJ PRICE	RCNLD



BLDG COMMENTS

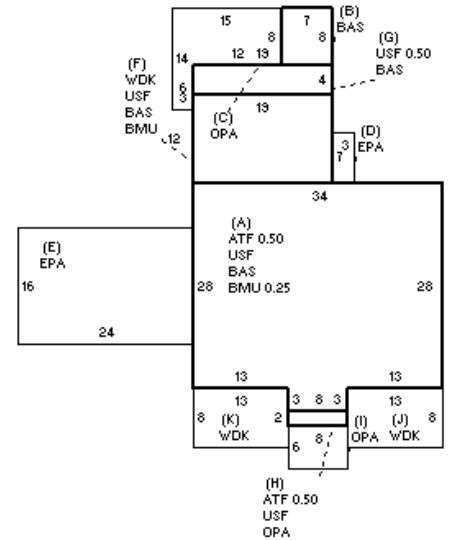

BUILDING	CD	ADJ	DESC	MEASURE	11/2/2022	JD
MODEL	1		RESIDENTIAL	LIST	11/2/2022	EST
STYLE	7	1.20	CONVENTIONAL [100%]	REVIEW	3/30/2011	KT
QUALITY	A	1.00	AVERAGE [100%]			
FRAME	1	1.00	WOOD FRAME [100%]			

YEAR BLT	1760	SIZE ADJ	1.000	ELEMENT	CD	DESCRIPTION	ADJ	S	BAT	T	DESCRIPTION	UNITS	YB	ADJ PRICE	RCN
NET AREA	3,090	DETAIL ADJ	1.248	FOUNDATION	5	BRICK/STONE	1.00	+	BMU	N	BSMT UNFINISHED	472		62.22	29,370
\$NLA(RCN)	\$252	OVERALL	1.000	EXT COVER	4	VINYL	1.00	+	USF	L	UPPER STORY FIN	1,258	1760	213.88	269,064
CAPACITY			UNITS	ADJ	ROOF SHAPE	1	1.00	+	ATF	L	ATTIC FINISH	496	1760	151.96	75,372
STORIES	2.5	1.00	ROOF COVER	1	ASPH SHINGLES	1.00	1.00	+	BAS	L	BASE AREA	1,336	1760	235.19	314,217
ROOMS	12	1.00	FLOOR COVER	24	COMB	1.00	1.00	+	OPA	N	OPEN PORCH	202		51.50	10,403
BEDROOMS	0	1.00	INT FINISH	1	PLASTER	1.00	1.00	+	EPA	N	ENCLOSED PORCH	405		90.20	36,531
BATHROOMS	3	1.00	HEATING/COOLING	2	HOT WATER	1.02	1.02	+	WDK	N	WOOD DECK	436		38.40	16,742
# 1/2 BATHS	1	1.00	FUEL SOURCE	2	GAS	1.00	1.00		F21	O	FPL 2S 1OP	2		8,238.50	16,477
TOT FIXTURES	11	\$10,982													
# UNITS	2	1.02													

TOTAL RCN	779,158
CONDITION ELEM	CD
EXTERIOR	P
INTERIOR	P
KITCHEN	P
BATHS	P
HEAT	A
ELECT	A
EFF.YR/AGE	1954 / 68
COND	60 60 %
FUNC	0
ECON	0
DEPR	60 % GD 40
RCNLD	\$311,700