

Key: 2612

Town of SCITUATE - Fiscal Year 2024

10/18/2023 5:31 pm SEQ #: 2.519

LEGAL

CURRENT OWNER				PARCEL ID				LOCATION			
O'BRIEN MICHAEL C & JANICE M 15 CAVANAGH RD SCITUATE, MA 02066				7-8-11-0				15 CAVANAGH RD			
TRANSFER HISTORY				DOS	T	SALE PRICE	BK-PG (Cert)				
O'BRIEN MICHAEL C & JANICE				11/19/2021	O	373,500	56043-149				
O'BRIEN MICHAEL C TR &				12/23/2015	F	1	46419-117				
O'BRIEN MICHAEL C & JANICE				11/25/2009	A	125,000	37962-90				

CLASS	CLASS%	DESCRIPTION			BN ID	BN	CARD	
1010	100	SINGLE FAMILY				1	1 of 1	
PMT NO	PMT DT	TY	DESC	AMOUNT	INSP	BY	1st	%
22-1323	12/22/2022	1	NEW CONST	525,000	04/19/2023	JD	65	65
	06/01/2022	7	OTHERS		05/25/2022	JD	100	0
	06/01/2022	7	OTHERS		11/02/2022	JD	100	100

LAND

CD	T	AC/SF/UN	Ngh	Inf1	Inf2	ADJ BASE	SAF	Inf3	Lpi	VC	CREDIT AMT	ADJ VALUE	
100	S	30,006	NS 1.00	100	1.00	100	1.00	528,000	1.29	100	1.00	R05 1.20	469,690

TOTAL	30,006 SF	ZONING	FRNT	324	ASSESSED	CURRENT	PREVIOUS
Ngh	NO. SCITUATE	NOTE			LAND	469,700	427,000
Inf1	FACTOR 100		BUILDING	548,300	45,100		
Inf2	PHY 100		DETACHED	0	0		
			OTHER	0	0		
			TOTAL		1,018,000	472,100	

DETACHED

TY	QUAL	COND	DIM/NOTE	YB	UNITS	ADJ PRICE	RCNLD

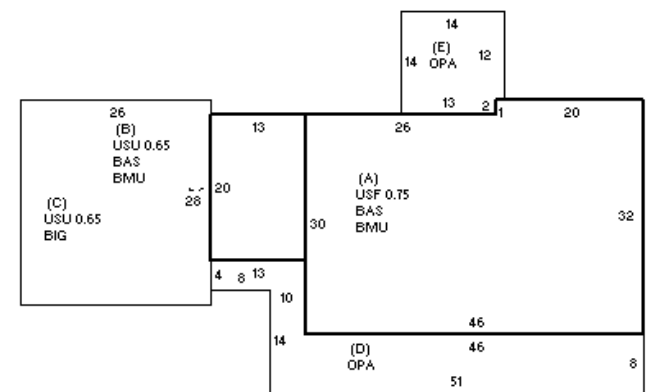

BUILDING

BUILDING	CD	ADJ	DESC	MEASURE	4/19/2023	JD
MODEL	1		RESIDENTIAL	LIST	4/19/2023	JD
STYLE	4	1.10	CAPE [100%]	REVIEW		
QUALITY	+	1.10	AVG +/GOOD - [100%]			
FRAME	1	1.00	WOOD FRAME [100%]			

BLDG COMMENTS

G

YEAR BLT	2023	SIZE ADJ	1.000	ELEMENT	CD	DESCRIPTION	ADJ	S	BAT	T	DESCRIPTION	UNITS	YB	ADJ PRICE	RCN	TOTAL RCN	843,613		
NET AREA	2,745	DETAIL ADJ	1.133	FOUNDATION	4	CONT BSMT WALL	1.00	+	BMU	N	BSMT UNFINISHED	1,680		45.85	77,023	CONDITION ELEM	CD		
\$NLA(RCN)	\$307	OVERALL	1.000	EXT COVER	1	WD SHINGLES	1.00	+	BAS	L	BASE AREA	1,680	2023	232.24	390,171	EXTERIOR	A		
				ROOF SHAPE	1	GABLE	1.00	A	USF	L	UPPER STORY FIN	1,065	2023	211.20	224,929	INTERIOR	A		
				ROOF COVER	1	ASPH SHINGLES	1.00	+	USU	N	UPPER STORY UNF	642		93.10	59,767	KITCHEN	A		
				FLOOR COVER			1.00	C	BIG	N	BUILT-IN GARAGE	728		50.68	36,892	BATHS	A		
				INT FINISH	1	PLASTER	1.00	+	OPA	N	OPEN PORCH	684		56.65	38,749	HEAT	A		
				HEATING/COOLING	9	WARM/COOL AIR	1.03		GFP	O	GAS FIREPLACE	1		6,111.60	6,112	ELECT	A		
				FUEL SOURCE	2	GAS	1.00												
																		EFF.YR/AGE	2022 / 0
																		COND	0 0 %
																		FUNC	35 uc
																		ECON	0
																		DEPR	35 % GD 65
																		RCNLD	\$548,300