

Key: 3054

Town of SCITUATE - Fiscal Year 2024

10/18/2023 5:31 pm SEQ #: 2.963

LEGALS

CURRENT OWNER				PARCEL ID				LOCATION			
PUTNAM CHRISTIAN A & KRISTEN E				5-3-21-0				81 GLADES RD			
81 GLADES RD				TRANSFER HISTORY				DOS	T	SALE PRICE	BK-PG (Cert)
SCITUATE, MA 02066				PUTNAM CHRISTIAN A & KRIS				05/14/2008	F	100	35966-044
				PUTNAM CHRISTIAN A				05/31/2001	QS	289,000	19931-245
				SPRAGUE DAVID C				02/28/1999	QS	17131-292	

CLASS	CLASS%	DESCRIPTION		BN ID	BN	CARD	
1010	100	SINGLE FAMILY			1	1 of 1	
PMT NO	PMT DT	TY	DESC	AMOUNT	INSP	BY	1st %
19-474	06/24/2019	2	ADDITIONS	85,000	08/25/2020	JD	100 100
13-206	04/16/2013	3	ALTERATIONS	5,000	06/18/2013	SJ	100 100
08-271	06/01/2008	2	ADDITIONS	40,000	06/10/2009	SJ	100 100
98-572	11/06/1998	3	ALTERATIONS	4,000			100 100
95-578	10/05/1995	3	ALTERATIONS	2,000			100 100

LAND

CD	T	AC/SF/UN	Ngh	Infl1	Infl2	ADJ BASE	SAF	Infl3	Lpi	VC	CREDIT AMT	ADJ VALUE
100	S	6,471	MB	1.00	100	1.00	100	1.00	1.00	WV3	1.50	530,180

TOTAL	6,471 SF	ZONING	FRNT	26	ASSESSED	CURRENT	PREVIOUS
Ngh	MINOT BCH	N O T E	IN M8...INFL3 REMOVED (FY12) MERGED WITH LOT 5-3-20-0 FY19		LAND	530,200	417,700
Infl1	FACTOR 100		BUILDING	311,000	276,600		
Infl2	PHY 100		DETACHED	0	0		
			OTHER	0	0		
<b>TOTAL</b>						<b>841,200</b>	<b>694,300</b>

DETACHED

TY	QUAL	COND	DIM/NOTE	YB	UNITS	ADJ PRICE	RCNLD

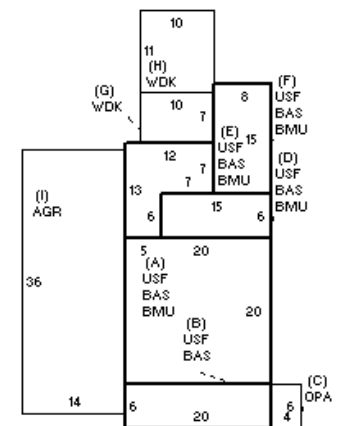

BUILDING

BUILDING	CD	ADJ	DESC	MEASURE	8/25/2020	JD
MODEL	1		RESIDENTIAL	LIST	8/25/2020	EST
STYLE	7	1.20	CONVENTIONAL [100%]	REVIEW	9/5/2019	JD
QUALITY	A	1.00	AVERAGE [100%]			
FRAME	1	1.00	WOOD FRAME [100%]			

BLDG COMMENTS		

G

YEAR BLT	1900	SIZE ADJ	1.000	ELEMENT	CD	DESCRIPTION	ADJ	S	BAT	T	DESCRIPTION	UNITS	YB	ADJ PRICE	RCN	TOTAL RCN	485.956		
NET AREA	1,688	DETAIL ADJ	1.224	FOUNDATION	4	CONT BSMT WALL	1.00	+	BMU	N	BSMT UNFINISHED	724		52.29	37,857	CONDITION ELEM	CD		
\$NLA(RCN)	\$288	OVERALL	1.000	EXT COVER	1	WD SHINGLES	1.00	+	USF	L	UPPER STORY FIN	844	1900	232.06	195,858	EXTERIOR	A		
				ROOF SHAPE	1	GABLE	1.00	+	BAS	L	BASE AREA	844	1900	255.18	215,373	INTERIOR	A		
				ROOF COVER	1	ASPH SHINGLES	1.00	C	OPA	N	OPEN PORCH	24		51.50	1,236	KITCHEN	A		
				FLOOR COVER	24	COMB	1.00	+	WDK	N	WOOD DECK	180		38.40	6,912	BATHS	A		
				INT FINISH	2	DRYWALL	1.00	I	AGR	N	ATT GARAGE	504		44.01	22,182	HEAT	A		
				HEATING/COOLING	2	HOT WATER	1.02		ODS	O	OUT DOOR SHOWER	1		1,642.00	1,642	ELECT	A		
				FUEL SOURCE	2	GAS	1.00												
																		EFF.YR/AGE	1968 / 54
																		COND	36 36%
																		FUNC	0
																		ECON	0
																		DEPR	36 % GD 64
																		RCNLD	\$311,000