

Key: 3080

Town of SCITUATE - Fiscal Year 2024

10/18/2023 5:31 pm SEQ #: 2.986

LEGALLAND

CURRENT OWNER				PARCEL ID				LOCATION			
GILLESPIE DONALD F & JOAN M 44 OCEAN AV SCITUATE, MA 02066				8-7-24-0				44 OCEAN AV			
TRANSFER HISTORY				DOS	T	SALE PRICE	BK-PG (Cert)				
GILLESPIE DONALD F & JOAN				06/20/2018	G	2,000,000	49939-199				
HENNESSY JOHN G & SHARON				11/19/1993	QS	365,000	12406-164				
GORDON MARY				01/01/1951	XX		2094-388				

CLASS	CLASS%	DESCRIPTION			BN ID	BN	CARD	
1010	100	SINGLE FAMILY				1	1 of 1	
PMT NO	PMT DT	TY	DESC	AMOUNT	INSP	BY	1st	%
21-606	06/10/2021	2	ADDITIONS	88,120	02/17/2022	JD	100	30
21-606	06/10/2021	1	NEW CONST	88,120	05/24/2022	JD	100	50
21-606	06/10/2021	1	NEW CONST	88,120	11/02/2022	JD	100	100
20-218	04/09/2020	1	NEW CONST	428,000	05/21/2020	JD	100	5
20-218	04/09/2020	1	NEW CONST	428,000	03/30/2021	JD	100	70

CD	T	AC/SF/UN	Ngh	Inf1	Inf2	ADJ BASE	SAF	Inf3	Lpi	VC	CREDIT AMT	ADJ VALUE
100	S	34,379	MB	1.00	100	1,100,000	1.14	100	1.00	R07	2.50	992,480

TOTAL	34,379 SF	ZONING	FRNT	646	ASSESSED	CURRENT	PREVIOUS
Ngh	MINOT BCH	NOTE	LAND	992,500	902,300		
Inf1	FACTOR 100		BUILDING	1,854,100	1,547,300		
Inf2	PHY 100		DETACHED	31,400	16,700		
			OTHER	0	0		
			<b>TOTAL</b>	<b>2,878,000</b>	<b>2,466,300</b>		

TY	QUAL	COND	DIM/NOTE	YB	UNITS	ADJ PRICE	RCNLD
IPG	G	1.20	10 0.90	38X18	2022	684 41.99	25,800
HTB	G	1.20	10 0.90		2022	1 6,218.16	5,600



BUILDING	CD	ADJ	DESC	MEASURE	3/30/2021	JD
MODEL	1		RESIDENTIAL	LIST	3/30/2021	EST
STYLE	20	1.35	NEW STYLE [100%]	REVIEW	11/2/2022	JD
QUALITY	V	1.40	VERY GOOD [100%]			
FRAME	1	1.00	WOOD FRAME [100%]			

YEAR BLT	2020	SIZE ADJ	1.000	ELEMENT	CD	DESCRIPTION	ADJ	S	BAT	T	DESCRIPTION	UNITS	YB	ADJ PRICE	RCN	TOTAL RCN	1,891,987
NET AREA	4,851	DETAIL ADJ	1.390	FOUNDATION	4	CONT BSMT WALL	1.00	+	BMU	N	BSMT UNFINISHED	2,266		55.46	125,678		
\$NLA(RCN)	\$390	OVERALL	1.000	EXT COVER	1	WD SHINGLES	1.00	+	USF	L	UPPER STORY FIN	2,551	2020	318.21	811,754		
				ROOF SHAPE	1	GABLE	1.00	B	BIG	N	BUILT-IN GARAGE	676		80.24	54,243		
				ROOF COVER	1	ASPH SHINGLES	1.00	C	EPA	N	ENCLOSED PORCH	252		126.28	31,822		
				FLOOR COVER	12	COMB	1.00	+	OPA	N	OPEN PORCH	343		72.10	24,731		
				INT FINISH	2	DRYWALL	1.00	+	BAS	L	BASE AREA	2,300	2020	349.91	804,804		
				HEATING/COOLING	9	WARM/COOL AIR	1.03		FPL	O	FIREPLACE	1		10,938.20	10,938		
				FUEL SOURCE	2	GAS	1.00		GEN	O	GENERATOR	1		0.00			
									GFP	O	GAS FIREPLACE	1		7,778.40	7,778		

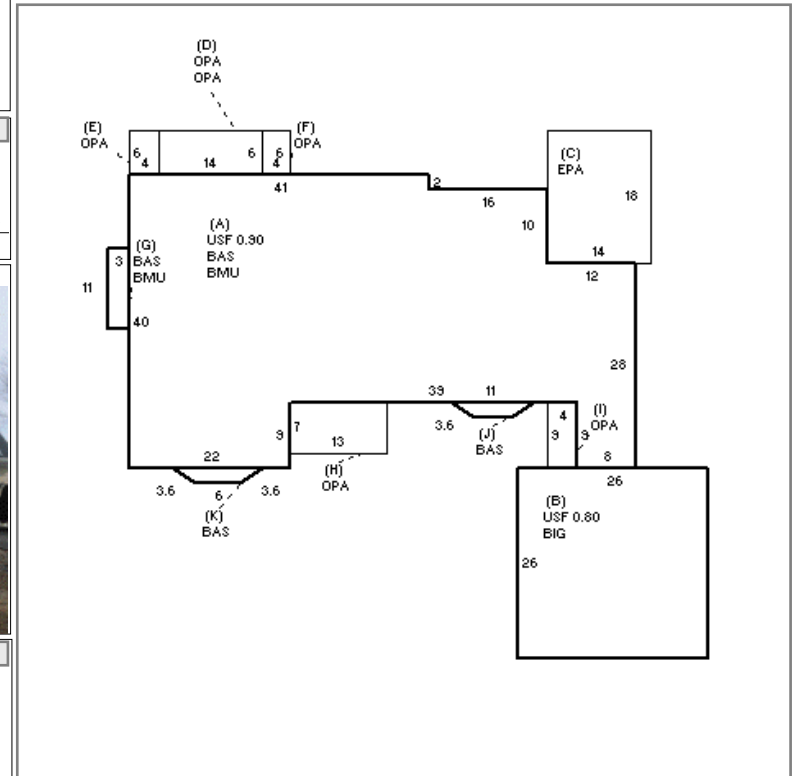

DETACHED

BUILDING

LOADING

CONDITION ELEM	CD
EXTERIOR	A
INTERIOR	A
KITCHEN	A
BATHS	A
HEAT	A
ELECT	A

EFF.YR/AGE	2020 / 2	
COND	2	2 %
FUNC	0	
ECON	0	
DEPR	2	% GD 98
RCNLD	\$1,854,100	