

Key: 3111

Town of SCITUATE - Fiscal Year 2024

10/18/2023 5:31 pm SEQ #: 3.018

LEGALS

CURRENT OWNER				PARCEL ID				LOCATION			
GLANCY J JR & DOROTHY L 28 WHITCOMB ROAD SCITUATE, MA 02066				7-6-17-0				28 WHITCOMB RD			
TRANSFER HISTORY				DOS	T	SALE PRICE	BK-PG (Cert)				
GLANCY J JR & DOROTHY L				01/07/2003	P	380,000	23879-347				
BARRY JOHN S				08/05/2002	XX		22572-15				
BARRY JOHN S TRUSTEE				05/03/2002	G	320,000	22027-263				

CLASS	CLASS%	DESCRIPTION			BN ID	BN	CARD	
1010	100	SINGLE FAMILY				1	1 of 1	
PMT NO	PMT DT	TY	DESC	AMOUNT	INSP	BY	1st	%
03-252	05/20/2003	1	NEW CONST	232,000	06/29/2004	SJ	100	100
09-300	06/01/1989	3	ALTERATIONS				100	100

LAND

CD	T	AC/SF/UN	Ngh	Inf1	Inf2	ADJ BASE	SAF	Inf3	Lpi	VC	CREDIT AMT	ADJ VALUE
100	S	8,380	MB 1.00	100	1.00	1,100,000	4.23	100	1.00	R07	2.50	894,670

DETACHED

TOTAL	8,364 SF		ZONING	FRNT	46	ASSESSED	CURRENT	PREVIOUS
Ngh	MINOT BCH		N O T E	IN M8....		LAND	894,700	813,300
Inf1	FACTOR 100			BUILDING	587,800	552,100		
Inf2	PHY 100			DETACHED	1,100	1,000		
				OTHER	0	0		
				<b>TOTAL</b>		<b>1,483,600</b>	<b>1,366,400</b>	

TY	QUAL	COND	DIM/NOTE	YB	UNITS	ADJ PRICE	RCNLD
S/V	A	1.00	SV 1.00 SHED	2003	1,000	1.10	1,100



BLDG COMMENTS  
OTHER FIX=SHOWER  
FY12 QUALITY CHANGE FROM VGD TO GD PER FIELD REVIEW. STYLE CHANGE FROM COL TO CONV.

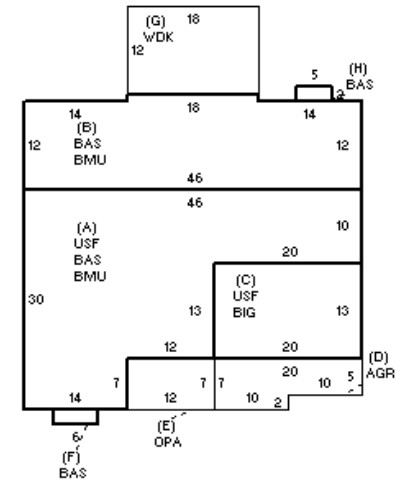

BUILDING

BUILDING	CD	ADJ	DESC	MEASURE	8/31/2010	PL
MODEL	1		RESIDENTIAL	LIST	8/31/2010	EST
STYLE	5	1.00	COLONIAL [100%]	REVIEW	4/5/2011	KT
QUALITY	G	1.20	GOOD [100%]			
FRAME	1	1.00	WOOD FRAME [100%]			

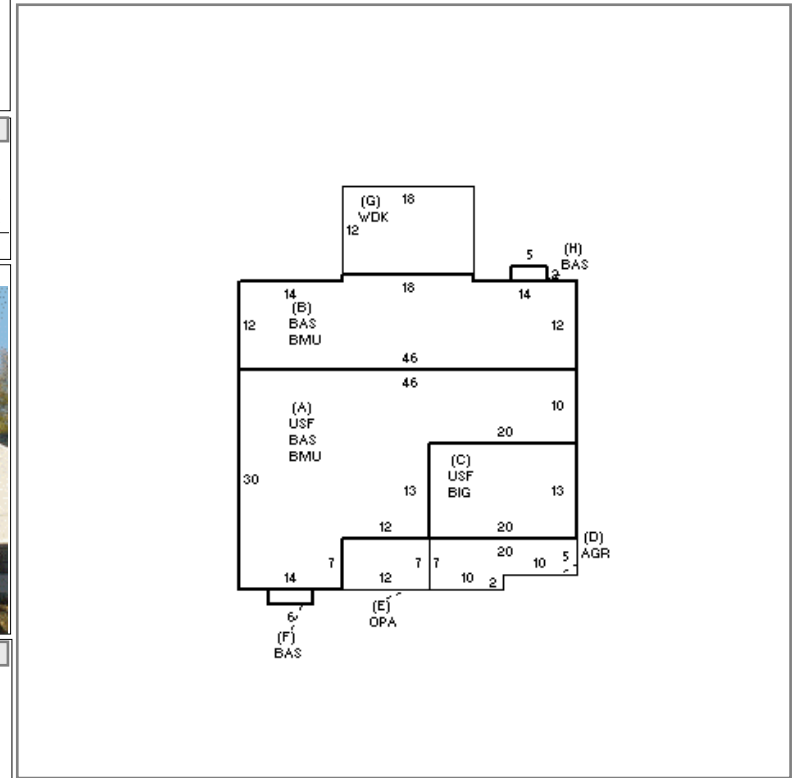

INDING

YEAR BLT	2003	SIZE ADJ	1.000	ELEMENT	CD	DESCRIPTION	ADJ	S	BAT	T	DESCRIPTION	UNITS	YB	ADJ PRICE	RCN	TOTAL RCN	725,624
NET AREA	2,644	DETAIL ADJ	1.030	FOUNDATION	4	CONT BSMT WALL	1.00	+	BMU	N	BSMT UNFINISHED	1,466		51.43	75,396		
\$NLA(RCN)	\$274	OVERALL	1.000	EXT COVER	1	WD SHINGLES	1.00	+	USF	L	UPPER STORY FIN	1,156	2003	216.33	250,074		
				ROOF SHAPE	1	GABLE	1.00	C	BIG	N	BUILT-IN GARAGE	260		58.81	15,292		
				ROOF COVER	1	ASPH SHINGLES	1.00	D	AGR	N	ATT GARAGE	120		57.10	6,852		
				FLOOR COVER	99	N/A	1.00	E	OPA	N	OPEN PORCH	84		61.80	5,191		
				INT FINISH	99	N/A	1.00	+	BAS	L	BASE AREA	1,488	2003	237.88	353,988		
				HEATING/COOLING	9	WARM/COOL AIR	1.03	G	WDK	N	WOOD DECK	216		46.08	9,953		
				FUEL SOURCE	99	N/A	1.00										

CONDITION ELEM	CD
EXTERIOR	
INTERIOR	
KITCHEN	
BATHS	
HEAT	
ELECT	

EFF.YR/AGE	2003 / 19	
COND	18	18 %
FUNC	0	
ECON	0	
DEPR	19	% GD 81
RCNLD	\$587,800	