

Key: 314

Town of SCITUATE - Fiscal Year 2024

10/18/2023 5:31 pm SEQ #: 301

LEGAL

CURRENT OWNER				PARCEL ID				LOCATION			
KRUSELL ERIC H & ANNE M TRS 72 CEDAR ST SCITUATE, MA 02066				17-1-5-0				72 CEDAR ST			
TRANSFER HISTORY				DOS	T	SALE PRICE		BK-PG (Cert)			
KRUSELL ERIC H & ANNE M T				01/13/2022	F	100		56310-103			
KRUSELL ERIC H & ANNE M T				01/03/2001	F	100		19232-8			
KRUSELL ERIC H AND ANNE				08/29/1990	XX			9917-227			

CLASS	CLASS%	DESCRIPTION			BN ID	BN	CARD	
1010	100	SINGLE FAMILY				1	1 of 1	
PMT NO	PMT DT	TY	DESC	AMOUNT	INSP	BY	1st	%
95-319	06/12/1995	3	ALTERATIONS				100	100
		6	CYCL GROWTH				100	100

LAND

CD	T	AC/SF/UN	Ngh	Inf1	Inf2	ADJ BASE	SAF	Inf3	Lpi	VC	CREDIT AMT	ADJ VALUE
100	S	40,000	WS 1.00	100	1.00	374,000	1.00	100	1.00	R03	0.85	343,430
300	A	1,260	WS 1.00	100	1.00	16,830	1.00	100	1.00	R03	0.85	21,210

TOTAL	2.178 Acres	ZONING	W. SCITUATE	FRNT	161	ASSESSED	364,600	CURRENT	617,300	PREVIOUS	568,100
Ngh	W. SCITUATE	NOTE	LAND			364,600			332,600		
Inf1	FACTOR 100		BUILDING			235,200			219,100		
Inf2	PHY 100		DETACHED			17,500			16,400		
			OTHER			0			0		
			TOTAL			617,300			568,100		

DETACHED

TY	QUAL	COND	DIM/NOTE	YB	UNITS	ADJ PRICE	RCNLD
GFU	L	0.80	60 0.40 GARAGE/LOFT		828	36.27	12,000
S/V	A	1.00	SV 1.00 SHED		5,000	1.10	5,500

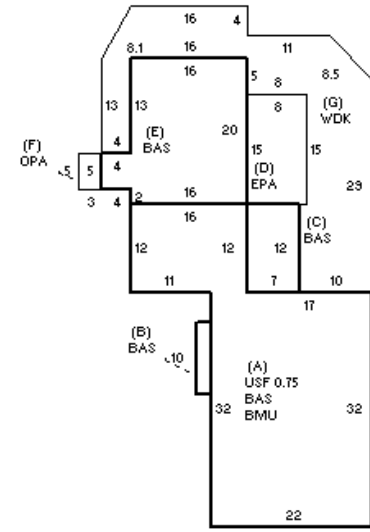

BUILDING

BUILDING	CD	ADJ	DESC	MEASURE	4/11/2011	PL
MODEL	1		RESIDENTIAL	LIST	4/11/2011	EST
STYLE	7	1.20	CONVENTIONAL [100%]	REVIEW	2/27/2018	JD
QUALITY	A	1.00	AVERAGE [100%]			
FRAME	1	1.00	WOOD FRAME [100%]			

BLDG COMMENTS

LOADING

YEAR BLT	1894	SIZE ADJ	1.000	ELEMENT	CD	DESCRIPTION	ADJ	S	BAT	T	DESCRIPTION	UNITS	YB	ADJ PRICE	RCN	TOTAL RCN	560,107		
NET AREA	2,012	DETAIL ADJ	1.224	FOUNDATION	5	BRICK/STONE	1.00	A	BMU	N	BSMT UNFINISHED	896		48.71	43,644	CONDITION ELEM	CD		
\$NLA(RCN)	\$278	OVERALL	1.000	EXT COVER	1	WD SHINGLES	1.00	A	USF	L	UPPER STORY FIN	672	1894	224.08	150,583	EXTERIOR			
				ROOF SHAPE	1	GABLE	1.00	+	BAS	L	BASE AREA	1,340	1894	246.41	330,187	INTERIOR			
				ROOF COVER	1	ASPH SHINGLES	1.00	D	EPA	N	ENCLOSED PORCH	120		90.20	10,824	KITCHEN			
				FLOOR COVER	99	N/A	1.00	F	OPA	N	OPEN PORCH	15		51.53	773	BATHS			
				INT FINISH	99	N/A	1.00	G	WDK	N	WOOD DECK	551		38.40	21,158	HEAT			
				HEATING/COOLING	2	HOT WATER	1.02									ELECT			
				FUEL SOURCE	99	N/A	1.00												
																	EFF.YR/AGE	1955 / 67	
																	COND	58 58 %	
																	FUNC	0	
																	ECON	0	
																	DEPR	58 % GD 42	
																	RCNLD	\$235,200	