

Key: 326

Town of SCITUATE - Fiscal Year 2024

10/18/2023 5:31 pm SEQ #: 313

LEGAL

CURRENT OWNER				PARCEL ID				LOCATION			
HOFFMAN MARA 34 STEARNS ROAD SCITUATE, MA 02066				42-3-26-0				34 STEARNS RD			
TRANSFER HISTORY				DOS	T	SALE PRICE	BK-PG (Cert)				
HOFFMAN MARA				05/21/1999	QS	267,000	17480-267				
TARMEY THOMAS & MARGARET				01/01/1976	XX		4070-600				
MADSEN JOHN D AND JOAN F				01/01/1974	XX		3932-361				

CLASS	CLASS%	DESCRIPTION			BN ID	BN	CARD	
1010	100	SINGLE FAMILY				1	1 of 1	
PMT NO	PMT DT	TY	DESC	AMOUNT	INSP	BY	1st	%
05-059	02/15/2005	2	ADDITIONS	14,000	07/13/2007	SJ	100	100
		2	ADDITIONS		09/08/2006	SJ	100	100
		2	ADDITIONS		07/12/2005	SJ	100	100
05-059	02/15/2005	2	ADDITIONS		07/15/2008	SJ	100	100

LAND

CD	T	AC/SF/UN	Ngh	Inf1	Inf2	ADJ BASE	SAF	Inf3	Lpi	VC	CREDIT AMT	ADJ VALUE
100	S	40,000	WS 1.00	100	1.00	440,000	1.00	100	1.00	R04	1.00	404,040
300	A	0.002	WS 1.00	100	1.00	19,800	1.00	100	1.00	R04	1.00	40

DETACHED

TOTAL	40,075 SF	ZONING	FRNT	176	ASSESSED	CURRENT	PREVIOUS
Ngh	W. SCITUATE	NOTE			LAND	404,100	367,400
Inf1	FACTOR 100		LAND BUILDING	461,500	425,400		
Inf2	PHY 100		DETACHED	1,300	1,200		
			OTHER	0	0		
			TOTAL	866,900	794,000		

TY	QUAL	COND	DIM/NOTE	YB	UNITS	ADJ PRICE	RCNLD
S/V	A	1.00	SV 1.00 SHED		1,200	1.10	1,300



BLDG COMMENTS
FY12 QUALITY CHANGE FROM GD TO AVG+ PER FIELD REVIEW.

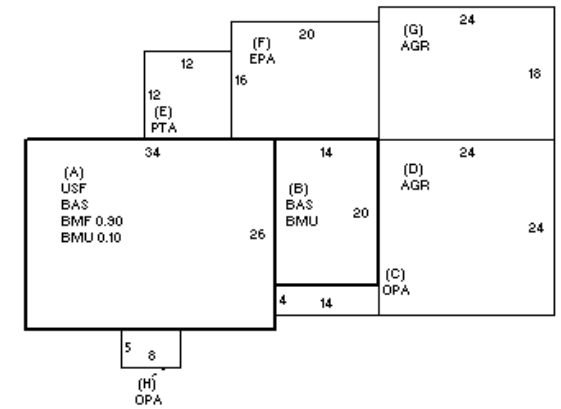

BUILDING

BUILDING	CD	ADJ	DESC	MEASURE	7/20/2010	PL
MODEL	1		RESIDENTIAL	LIST	7/20/2010	EST
STYLE	5	1.00	COLONIAL [100%]	REVIEW	3/7/2011	KT
QUALITY	+	1.10	AVG +/GOOD - [100%]			
FRAME	1	1.00	WOOD FRAME [100%]			

G

YEAR BLT	1965	SIZE ADJ	1.000
NET AREA	2,048	DETAIL ADJ	1.020
\$NLA(RCN)	\$304	OVERALL	1.000

CAPACITY	UNITS	ADJ
STORIES	2	1.00
ROOMS	8	1.00
BEDROOMS	4	1.00
BATHROOMS	2	1.00
# 1/2 BATHS	1	1.00
TOT FIXTURES	8	\$7,181
# UNITS	1	1.00

ELEMENT	CD	DESCRIPTION	ADJ
FOUNDATION	4	CONT BSMT WALL	1.00
EXT COVER	2	CLAPBOARD	1.00
ROOF SHAPE	2	HIP	1.00
ROOF COVER	1	ASPH SHINGLES	1.00
FLOOR COVER	99	N/A	1.00
INT FINISH	99	N/A	1.00
HEATING/COOLING	2	HOT WATER	1.02
FUEL SOURCE	99	N/A	1.00

S	BAT	T	DESCRIPTION	UNITS	YB	ADJ PRICE	RCN
+	BMU	N	BSMT UNFINISHED	368		49.78	18,321
A	BMF	N	BSMT FINISH-SEP	796		69.89	55,629
+	BAS	L	BASE AREA	1,164	1965	225.16	262,092
A	USF	L	UPPER STORY FIN	884	1965	204.76	181,011
+	OPA	N	OPEN PORCH	96		56.65	5,438
+	AGR	N	ATT GARAGE	1,008		42.40	42,737
E	PTA	N	PATIO	144		16.39	2,361
F	EPA	N	ENCLOSED PORCH	320		99.22	31,750
	F11	O	FPL 1S 1OP	1		8,009.10	8,009
	F21	O	FPL 2S 1OP	1		9,062.90	9,063

TOTAL RCN	623,591
CONDITION ELEM	CD
EXTERIOR	
INTERIOR	
KITCHEN	
BATHS	
HEAT	
ELECT	
EFF.YR/AGE	1985 / 37
COND	26 26 %
FUNC	0
ECON	0
DEPR	26 % GD 74
RCNLD	\$461,500