

Key: 3317

Town of SCITUATE - Fiscal Year 2024

10/18/2023 5:31 pm SEQ #: 3.198

LEGAL

CURRENT OWNER				PARCEL ID				LOCATION			
THOMPSON DENNIS & PAULA 4 CURTIS ROAD SCITUATE, MA 02066				28-18-11-0				4 CURTIS RD			
TRANSFER HISTORY				DOS	T	SALE PRICE		BK-PG (Cert)			
THOMPSON DENNIS & PAULA				01/01/1976	QS			5162-155			

CLASS	CLASS%	DESCRIPTION			BN ID	BN	CARD	
1010	100	SINGLE FAMILY				1	1 of 1	
PMT NO	PMT DT	TY	DESC	AMOUNT	INSP	BY	1st	%
05-198	05/03/2005	3	ALTERATIONS	38,000	07/08/2005	SJ	100	100
88-618	10/01/1988	2	ADDITIONS				100	100

LAND

CD	T	AC/SF/UN	Ngh	Inf1	Inf2	ADJ BASE	SAF	Inf3	Lpi	VC	CREDIT AMT	ADJ VALUE
100	S	14,981	OS 1.00	100	1.00	440,000	2.45	100	1.00	R03	1.00	370,020

TOTAL	14,981 SF	ZONING	FRNT	245	ASSESSED	CURRENT	PREVIOUS
Ngh	OCEANSIDE	NOTE			LAND	370,000	336,400
Inf1	FACTOR 100				BUILDING	378,500	354,000
Inf2	PHY 100				DETACHED	400	400
					OTHER	0	0
					TOTAL	748,900	690,800

DETAILED

TY	QUAL	COND	DIM/NOTE	YB	UNITS	ADJ PRICE	RCNLD
S/V	A	1.00	SV 1.00 SHED	1985	400	1.10	400

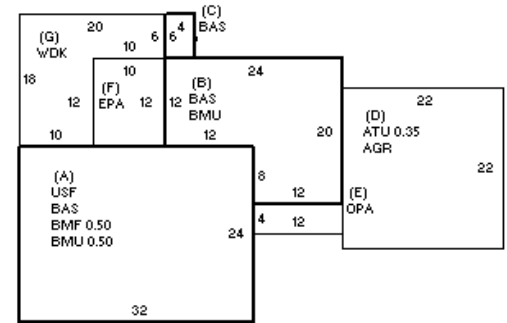

BUILDING

BUILDING	CD	ADJ	DESC	MEASURE	4/13/2009	PL
MODEL	1		RESIDENTIAL	LIST REVIEW	4/6/2011	KT
STYLE	5	1.00	COLONIAL [100%]			
QUALITY	A	1.00	AVERAGE [100%]			
FRAME	1	1.00	WOOD FRAME [100%]			

BLDG COMMENTS
FY12 QUALITY CHANGE FROM GD TO AVG PER FIELD REVIEW.

LOADING

YEAR BLT	1976	SIZE ADJ	1.000	ELEMENT	CD	DESCRIPTION	ADJ	S	BAT	T	DESCRIPTION	UNITS	YB	ADJ PRICE	RCN	TOTAL RCN	504,622	
NET AREA	1,944	DETAIL ADJ	1.000	FOUNDATION	4	CONT BSMT WALL	1.00	+	BMU	N	BSMT UNFINISHED	768		45.38	34,855	CONDITION ELEM	CD	
\$NLA(RCN)	\$260	OVERALL	1.000	EXT COVER	2	CLAPBOARD	1.00	A	BMF	N	BSMT FINISH-SEP	384		63.71	24,465	EXTERIOR		
				ROOF SHAPE	3	GAMBREL	1.00	A	USF	L	UPPER STORY FIN	768	1976	184.22	141,484	INTERIOR		
				ROOF COVER	1	ASPH SHINGLES	1.00	+	BAS	L	BASE AREA	1,176	1976	202.58	238,233	KITCHEN		
				FLOOR COVER	99	N/A	1.00	D	AGR	N	ATT GARAGE	484		44.45	21,515	BATHS		
				INT FINISH	99	N/A	1.00	D	ATU	N	ATTIC UNF	169		37.00	6,253	HEAT		
				HEATING/COOLING	1	FORCED AIR	1.00	E	OPA	N	OPEN PORCH	48		51.50	2,472	ELECT		
				FUEL SOURCE	99	N/A	1.00	F	EPA	N	ENCLOSED PORCH	120		90.20	10,824			
									G	WDK	N	WOOD DECK	240		38.40	9,216		
										F22	O	FPL 2S 2OP	1		11,305.00	11,305		
													EFF.YR/AGE	1990 / 32				
													COND	25 25%				
													FUNC	0				
													ECON	0				
													DEPR	25 % GD 75				
													RCNLD	\$378,500				