

Key: 336

Town of SCITUATE - Fiscal Year 2024

10/18/2023 5:31 pm SEQ #: 322

LEG
A
L
L
A
N
D

| CURRENT OWNER | | | | PARCEL ID | | | | LOCATION | | | | |
|--|---|----------|---------|------------|------|-------------|--------------|---------------|------|-----|------------|-----------|
| BAIRD PATRICIA W TR 111 SUMMER ST SCITUATE, MA 02066 | | | | 17-1-2-0 | | | | 111 SUMMER ST | | | | |
| TRANSFER HISTORY | | | | DOS | T | SALE PRICE | BK-PG (Cert) | | | | | |
| BAIRD PATRICIA W TR | | | | 06/30/2020 | V | 1 52997-1 | | | | | | |
| BAIRD PATRICIA W & WILLIA | | | | 11/12/2019 | V | 1 51931-128 | | | | | | |
| BAIRD PATRICIA W TR | | | | 05/24/2018 | V | 1 49834-57 | | | | | | |
| CD | T | AC/SF/UN | Ngh | Inf1 | Inf2 | ADJ BASE | SAF | Inf3 | Lpi | VC | CREDIT AMT | ADJ VALUE |
| 100 | S | 40,000 | WS 1.00 | 100 | 1.00 | 374,000 | 1.00 | 100 | 1.00 | R03 | 0.85 | 343,430 |
| 300 | A | 0.132 | WS 1.00 | 100 | 1.00 | 16,830 | 1.00 | 100 | 1.00 | R03 | 0.85 | 2,220 |

| CLASS | CLASS% | DESCRIPTION | | | BN ID | BN | CARD | |
|---------|------------|---------------|-------------|--------|------------|----|--------|-----|
| 1010 | 100 | SINGLE FAMILY | | | | 1 | 1 of 1 | |
| PMT NO | PMT DT | TY | DESC | AMOUNT | INSP | BY | 1st | % |
| 22-0805 | 07/27/2022 | 2 | ADDITIONS | 22,000 | 11/29/2022 | JD | 100 | 100 |
| 14-83 | 11/12/2014 | 3 | ALTERATIONS | 5,000 | 07/09/2015 | SJ | 100 | 100 |
| 09-365 | 08/12/2009 | 3 | ALTERATIONS | 2,550 | 06/23/2010 | SJ | 100 | 100 |
| 04-271 | 05/10/2004 | 7 | OTHERS | | | | 100 | 100 |
| 89-162 | 04/01/1989 | 3 | ALTERATIONS | | | | 100 | 100 |

D
E
T
A
C
H
E
D

| TOTAL | 1.050 Acres | ZONING | FRNT | 90 | ASSESSED | CURRENT | PREVIOUS |
|-------|-------------|------------------|-------------------------|----|--------------|----------------|----------------|
| Ngh | W. SCITUATE | N O T E | ...17-4-22 MULTI PARCEL | | LAND | 345,700 | 314,300 |
| Inf1 | FACTOR 100 | | LAND | | BUILDING | 327,900 | 250,200 |
| Inf2 | PHY 100 | | OTHER | | | 0 | 0 |
| | | | | | TOTAL | 710,300 | 584,000 |

| TY | QUAL | COND | DIM/NOTE | YB | UNITS | ADJ PRICE | RCNLD |
|-----|------|------|---------------|------|-------|-----------|--------|
| LBN | G | 1.20 | 30 0.70 30x26 | 1880 | 780 | 39.06 | 21,300 |
| SHF | A | 1.00 | 30 0.70 14X14 | 2003 | 196 | 12.33 | 1,700 |
| DDK | A | 1.00 | 30 0.70 8X5 | | 40 | 28.44 | 800 |
| DGF | A | 1.00 | 30 0.70 12X30 | | 360 | 51.11 | 12,900 |



BLDG COMMENTS

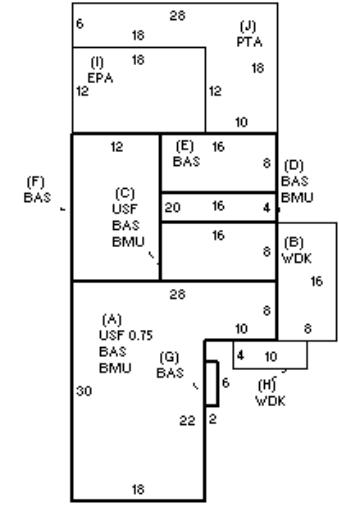

B
U
I
L
D
I
N
G

| BUILDING | CD | ADJ | DESC | MEASURE | 11/29/2022 | JD |
|----------|----|------|---------------------|---------|------------|-----|
| MODEL | 1 | | RESIDENTIAL | LIST | 11/29/2022 | EST |
| STYLE | 7 | 1.20 | CONVENTIONAL [100%] | REVIEW | 3/7/2011 | KT |
| QUALITY | A | 1.00 | AVERAGE [100%] | | | |
| FRAME | 1 | 1.00 | WOOD FRAME [100%] | | | |

| YEAR BLT | 1900 | SIZE ADJ | 1.000 | ELEMENT | CD | DESCRIPTION | ADJ | S | BAT | T | DESCRIPTION | UNITS | YB | ADJ PRICE | RCN | TOTAL RCN | 512,365 |
|------------|-------|------------|-------|-----------------|----|---------------|------|---|-----|---|-----------------|-------|------|-----------|---------|----------------|------------|
| NET AREA | 1,785 | DETAIL ADJ | 1.224 | FOUNDATION | 5 | BRICK/STONE | 1.00 | + | BMU | N | BSMT UNFINISHED | 812 | | 50.27 | 40,817 | | |
| \$NLA(RCN) | \$287 | OVERALL | 1.000 | EXT COVER | 1 | WD SHINGLES | 1.00 | + | USF | L | UPPER STORY FIN | 593 | 1900 | 229.24 | 135,942 | | |
| | | | | ROOF SHAPE | 1 | GABLE | 1.00 | + | WDK | N | WOOD DECK | 168 | | 38.40 | 6,451 | | |
| | | | | ROOF COVER | 1 | ASPH SHINGLES | 1.00 | + | BAS | L | BASE AREA | 1,192 | 1900 | 252.08 | 300,485 | | |
| | | | | FLOOR COVER | 24 | COMB | 1.00 | I | EPA | N | ENCLOSED PORCH | 216 | | 90.20 | 19,483 | | |
| | | | | INT FINISH | 1 | PLASTER | 1.00 | J | PTA | N | PATIO | 288 | | 14.90 | 4,291 | | |
| | | | | HEATING/COOLING | 2 | HOT WATER | 1.02 | | | | | | | | | | |
| | | | | FUEL SOURCE | 2 | GAS | 1.00 | | | | | | | | | | |
| | | | | | | | | | | | | | | | | CONDITION ELEM | CD |
| | | | | | | | | | | | | | | | | EXTERIOR | A |
| | | | | | | | | | | | | | | | | INTERIOR | A |
| | | | | | | | | | | | | | | | | KITCHEN | A |
| | | | | | | | | | | | | | | | | BATHS | A |
| | | | | | | | | | | | | | | | | HEAT | A |
| | | | | | | | | | | | | | | | | ELECT | A |
| | | | | | | | | | | | | | | | | EFF.YR/AGE | 1968 / 54 |
| | | | | | | | | | | | | | | | | COND | 36 36% |
| | | | | | | | | | | | | | | | | FUNC | 0 |
| | | | | | | | | | | | | | | | | ECON | 0 |
| | | | | | | | | | | | | | | | | DEPR | 36 % GD 64 |
| | | | | | | | | | | | | | | | | RCNLD | \$327,900 |