

Key: 34

Town of SCITUATE - Fiscal Year 2024

10/18/2023 5:31 pm SEQ #: 27

LEGAL

LAND

CURRENT OWNER				PARCEL ID				LOCATION			
GREENE MICHAEL J & S/O GREENE MICHAEL J & 56 INDIAN WIND DR SCITUATE, MA 02066				10-4-1-C				56 INDIAN WIND DR			
TRANSFER HISTORY				DOS	T	SALE PRICE	BK-PG (Cert)				
GREENE MICHAEL J & GREENE MICHAEL J & JACOBS ROBERT D & GAIL V				08/08/2023	F	10	58167-80				
				11/22/2013	QS	917,000	43850-7				
				07/31/2002	QS	905,000	22539-143				

CLASS	CLASS%	DESCRIPTION			BN ID	BN	CARD	
1010	100	SINGLE FAMILY				1	1 of 1	
PMT NO	PMT DT	TY	DESC	AMOUNT	INSP	BY	1st	%
22-1287	12/13/2022	3	ALTERATIONS	53,000	05/17/2023	NC	100	100
20-615	09/29/2020	3	ALTERATIONS	3,568	05/18/2021	JD	100	100
17-247	05/01/2017	3	ALTERATIONS	43,000	06/28/2017	SJ	100	100
11-786		2	ADDITIONS	7,000	06/26/2012	SJ	100	100
04-112	03/08/2004	3	ALTERATIONS	10,000	07/08/2004	SJ	100	100

CD	T	AC/SF/UN	Ngh	Inf1	Inf2	ADJ BASE	SAF	Inf3	Lpi	VC	CREDIT AMT	ADJ VALUE
100	S	40,000	WS 1.00	100	1.00	440,000	1.00	100	R05	1.00		404,040
300	A	0.262	WS 1.00	100	1.00	19,800	1.00	100	R05	1.00		5,190

TOTAL	1.180 Acres	ZONING	FRNT	356	ASSESSED	CURRENT	PREVIOUS
Ngh	W. SCITUATE	NOTE			LAND	409,200	372,300
Inf1	FACTOR 100		BUILDING	1,112,900	902,000		
Inf2	PHY 100		DETACHED	29,000	21,500		
			OTHER	0	0		
					TOTAL	1,551,100	1,295,800

DETAILED

TY	QUAL	COND	DIM/NOTE	YB	UNITS	ADJ PRICE	RCNLD
IPG	A	1.00	30 0.70 20X40	1999	800	33.98	19,000
CAB	A	1.00	30 0.70 18X22	1999	396	26.76	7,400
HTB	A	1.00	50 0.50 HOT TUB	1999	1	5,181.80	2,600

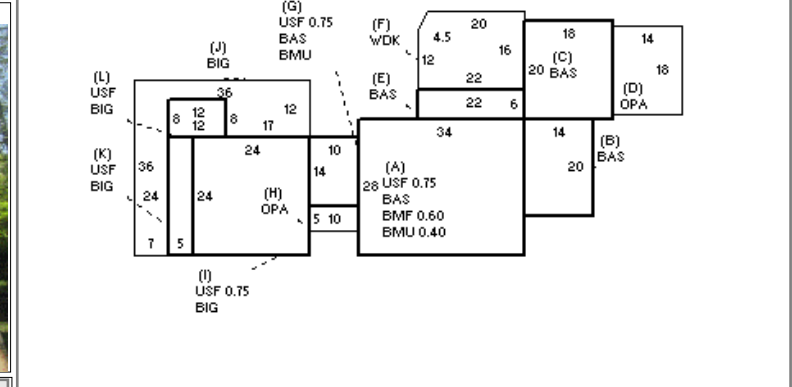

BUILDING

BUILDING	CD	ADJ	DESC	MEASURE	6/26/2012	SJ
MODEL	1		RESIDENTIAL	LIST		
STYLE	4	1.10	CAPE [100%]	REVIEW	6/27/2023	MR
QUALITY	V	1.40	VERY GOOD [100%]			
FRAME	1	1.00	WOOD FRAME [100%]			

BLDG COMMENTS

INDING

YEAR BLT	1994	SIZE ADJ	1.000	ELEMENT	CD	DESCRIPTION	ADJ	S	BAT	T	DESCRIPTION	UNITS	YB	ADJ PRICE	RCN	TOTAL RCN	1,196,714	
NET AREA	3,331	DETAIL ADJ	1.155	FOUNDATION	4	CONT BSMT WALL	1.00	+	BMU	N	BSMT UNFINISHED	521		64.42	33,564	CONDITION ELEM	CD	
\$NLA(RCN)	\$359	OVERALL	1.000	EXT COVER	2	CLAPBOARD	1.00	+	BMF	N	BSMT FINISH-SEP	571		90.43	51,638	EXTERIOR	G	
				ROOF SHAPE	1	GABLE	1.00	+	USF	L	UPPER STORY FIN	1,467	1994	274.64	402,899	INTERIOR	G	
				ROOF COVER	2	WOOD SHINGLES	1.01	+	BAS	L	BASE AREA	1,864	1994	302.00	562,937	KITCHEN	V	
				FLOOR COVER	99	N/A	1.00	+	OPA	N	OPEN PORCH	302		72.10	21,774	BATHS	V	
				INT FINISH	99	N/A	1.00	F	WDK	N	WOOD DECK	348		53.76	18,708	HEAT	U	
				HEATING/COOLING	11	HW/COOL AIR	1.04	+	BIG	N	BUILT-IN GARAGE	1,296		60.33	78,184	ELECT	A	
				FUEL SOURCE	1	OIL	1.00		F11	O	FPL 1S 1OP	1		10,193.40	10,193			
																	EFF.YR/AGE	2015 / 7
																	COND	7.7%
																	FUNC	0
																	ECON	0
																	DEPR	7% GD 93
																	RCNLD	\$1,112,900