

Key: 3507

Town of SCITUATE - Fiscal Year 2024

10/18/2023 5:31 pm SEQ #: 3366

LEGAL

CURRENT OWNER				PARCEL ID				LOCATION			
CARSON ROBERT D JR TR & JEAN B TR 4 CAIRO CIR SCITUATE, MA 02066				33-7-28-0				4 CAIRO CIR			
TRANSFER HISTORY				DOS	T	SALE PRICE	BK-PG (Cert)				
CARSON ROBERT D JR TR & CARSON ROBERT D JR & JEAN HENSCHEN RAYMOND C AND RI				04/09/2013	F	1 (118842)					
				09/17/1987	QS	218,500 (75929)					
				07/02/1981	XX	(C00065108)					

CLASS	CLASS%	DESCRIPTION			BN ID	BN	CARD	
1010	100	SINGLE FAMILY				1	1 of 1	
PMT NO	PMT DT	TY	DESC	AMOUNT	INSP	BY	1st	%
14-236	05/09/2014	3	ALTERATIONS	2,896	07/10/2014	MR	100	100
13-420	07/08/2013	3	ALTERATIONS	20,000	07/10/2014	MR	100	100
13-381	06/21/2013	3	ALTERATIONS	12,000	07/10/2014	MR	100	100
11-423	07/13/2011	3	ALTERATIONS	12,000	07/24/2012	SJ	100	100
09-427	09/17/2009	3	ALTERATIONS	19,800	08/05/2010	SJ	100	100

LAND

CD	T	AC/SF/UN	Ngh	Inf1	Inf2	ADJ BASE	SAF	Inf3	Lpi	VC	CREDIT AMT	ADJ VALUE
100	S	30,151	SC	1.00	100	1.00	100	1.00	R04	0.90		352,440

TOTAL	30,151 SF	ZONING	FRNT 105	ASSESSED		CURRENT		PREVIOUS	
Ngh	SCITUATE	N O T E	IN M34	LAND	352,400	338,200			
Inf1	FACTOR 100			BUILDING	373,500	349,800			
Inf2	PHY 100			DETACHED	0	0			
				OTHER	0	0			
				TOTAL	725,900	688,000			

DETACHED

TY	QUAL	COND	DIM/NOTE	YB	UNITS	ADJ PRICE	RCNLD

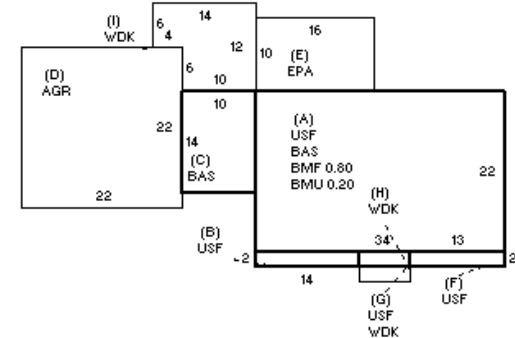

BUILDING

BUILDING	CD	ADJ	DESC	MEASURE	7/24/2012	SJ
MODEL	1		RESIDENTIAL	LIST	7/24/2012	EST
STYLE	5	1.00	COLONIAL [100%]	REVIEW	7/16/2014	TD
QUALITY	+	1.10	AVG +/GOOD - [100%]			
FRAME	1	1.00	WOOD FRAME [100%]			

BLDG COMMENTS

G

YEAR BLT	1964	SIZE ADJ	1.000	ELEMENT	CD	DESCRIPTION	ADJ	S	BAT	T	DESCRIPTION	UNITS	YB	ADJ PRICE	RCN	TOTAL RCN	498,054	
NET AREA	1,704	DETAIL ADJ	1.020	FOUNDATION	4	CONT BSMT WALL	1.00	A	BMU	N	BSMT UNFINISHED	150		56.87	8,531	CONDITION ELEM	CD	
\$NLA(RCN)	\$292	OVERALL	1.000	EXT COVER	1	WD SHINGLES	1.00	A	BMF	N	BSMT FINISH-SEP	598		79.83	47,740	EXTERIOR		
				ROOF SHAPE	1	GABLE	1.00	+	USF	L	UPPER STORY FIN	816	1964	212.29	173,230	INTERIOR		
				ROOF COVER	1	ASPH SHINGLES	1.00	+	BAS	L	BASE AREA	888	1964	233.44	207,297	KITCHEN		
				FLOOR COVER	34	COMB	1.00	D	AGR	N	ATT GARAGE	484		48.90	23,667	BATHS		
				INT FINISH	1	PLASTER	1.00	E	EPA	N	ENCLOSED PORCH	160		99.22	15,875	HEAT		
				HEATING/COOLING	2	HOT WATER	1.02	+	WDK	N	WOOD DECK	172		42.24	7,266	ELECT		
				FUEL SOURCE	99	N/A	1.00		F21	O	FPL 2S 1OP	1		9,062.90	9,063			
																	EFF.YR/AGE	1990 / 32
																	COND	25 25 %
																	FUNC	0
																	ECON	0
																	DEPR	25 % GD 75
																	RCNLD	\$373,500