

Key: 3753

Town of SCITUATE - Fiscal Year 2024

10/18/2023 5:31 pm SEQ #: 3.574

LEGAL

LAND

DETACHED

BUILDING

| CURRENT OWNER | | | | | | | | | | PARCEL ID | | | | LOCATION | | | |
|--|--|--|--|--|--|--|--|--|--|------------|----|---------------|--|---------------|--|--|--|
| GRISWOLD NANCY L & NORMAN J 310 TILDEN RD SCITUATE, MA 02066 | | | | | | | | | | 34-27-13-0 | | | | 310 TILDEN RD | | | |
| TRANSFER HISTORY | | | | | | | | | | DOS | T | SALE PRICE | | BK-PG (Cert) | | | |
| GRISWOLD NANCY L & NORMAN | | | | | | | | | | 11/07/2001 | F | 100 (100271) | | (100271) | | | |
| GRISWOLD LILLIAN M LE | | | | | | | | | | 11/07/2001 | F | -100 (100271) | | (100271) | | | |
| GRISWOLD PERLEY J & LILLI | | | | | | | | | | 01/01/1963 | XX | 32693-0 | | 32693-0 | | | |

| CLASS | CLASS% | DESCRIPTION | | | BN ID | BN | CARD | |
|---------|------------|---------------|-------------|--------|------------|----|--------|-----|
| 1010 | 100 | SINGLE FAMILY | | | | 1 | 1 of 1 | |
| PMT NO | PMT DT | TY | DESC | AMOUNT | INSP | BY | 1st | % |
| 22-0591 | 06/06/2022 | 3 | ALTERATIONS | 5,000 | 07/11/2022 | JD | 100 | 100 |
| 21-1588 | 12/22/2021 | 3 | ALTERATIONS | 11,500 | 07/11/2022 | JD | 100 | 100 |
| 90-22 | 01/30/1990 | 3 | ALTERATIONS | | | | 100 | 100 |

| CD | T | AC/SF/UN | Ngh | Inf1 | Inf2 | ADJ BASE | SAF | Inf3 | Lpi | VC | CREDIT AMT | ADJ VALUE | |
|-----|---|----------|---------|------|------|----------|------|---------|------|-----|------------|-----------|---------|
| 100 | S | 11,402 | OS 1.00 | 100 | 1.00 | 100 | 1.00 | 440,000 | 3.16 | 100 | 1.00 | R02 1.00 | 363,850 |

| TOTAL | 11,413 SF | ZONING | NOTED | FRNT | 241 | ASSESSED | CURRENT | PREVIOUS |
|--------------|------------|--------|----------------|----------------|---------|----------|---------|----------|
| Ngh | OCEANSIDE | NOTED | LAND | 363,900 | 330,800 | | | |
| Inf1 | FACTOR 100 | | BUILDING | 254,300 | 226,100 | | | |
| Inf2 | PHY 100 | | DETACHED | 0 | 0 | | | |
| | | | OTHER | 0 | 0 | | | |
| TOTAL | | | 618,200 | 556,900 | | | | |

| TY | QUAL | COND | DIM/NOTE | YB | UNITS | ADJ PRICE | RCNLD |
|----|------|------|----------|----|-------|-----------|-------|
| | | | | | | | |



BLDG COMMENTS

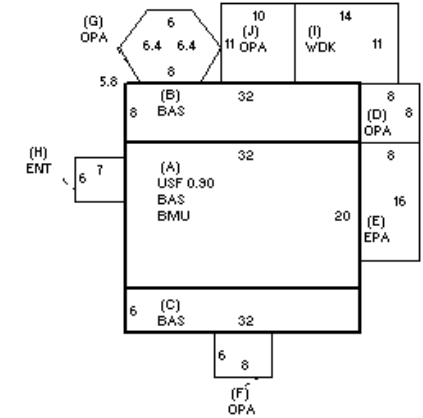

| BUILDING | CD | ADJ | DESC | MEASURE | 7/11/2022 | JD |
|----------|----|------|---------------------|---------|-----------|-----|
| MODEL | 1 | | RESIDENTIAL | LIST | 7/11/2022 | EST |
| STYLE | 7 | 1.20 | CONVENTIONAL [100%] | REVIEW | 4/6/2011 | ER |
| QUALITY | A | 1.00 | AVERAGE [100%] | | | |
| FRAME | 1 | 1.00 | WOOD FRAME [100%] | | | |

| YEAR BLT | 1930 | SIZE ADJ | 1.000 | ELEMENT | CD | DESCRIPTION | ADJ | S | BAT | T | DESCRIPTION | UNITS | YB | ADJ PRICE | RCN | |
|--------------|-------|------------|-----------------|------------|---------------|----------------|---------|------|------------|----------------|-----------------|-----------|-------|-----------|---------|---------|
| NET AREA | 1,664 | DETAIL ADJ | 1.200 | FOUNDATION | 4 | CONT BSMT WALL | 1.00 | A | BMU | N | BSMT UNFINISHED | 640 | | 54.73 | 35,027 | |
| \$NLA(RCN) | \$294 | OVERALL | 1.000 | EXT COVER | 2 | CLAPBOARD | 1.00 | A | USF | L | UPPER STORY FIN | 576 | 1930 | 228.20 | 131,443 | |
| CAPACITY | | | UNITS | ADJ | ROOF SHAPE | 3 | GAMBREL | 1.00 | + | BAS | L | BASE AREA | 1,088 | 1930 | 250.94 | 273,019 |
| STORIES | 1.9 | 1.00 | ROOF COVER | 1 | ASPH SHINGLES | 1.00 | + | OPA | N | OPEN PORCH | 327 | | 51.50 | 16,841 | | |
| ROOMS | 7 | 1.00 | FLOOR COVER | 2 | SOFTWOOD | 1.00 | E | EPA | N | ENCLOSED PORCH | 128 | | 90.20 | 11,546 | | |
| BEDROOMS | 4 | 1.00 | INT FINISH | 1 | PLASTER | 1.00 | H | ENT | N | ENCLOSED ENTRY | 42 | | 97.69 | 4,103 | | |
| BATHROOMS | 1 | 1.00 | HEATING/COOLING | 1 | FORCED AIR | 1.00 | I | WDK | N | WOOD DECK | 154 | | 38.40 | 5,914 | | |
| # 1/2 BATHS | 0 | 1.00 | FUEL SOURCE | 2 | GAS | 1.00 | F21 | O | FPL 2S 1OP | 1 | | 8,239.00 | 8,239 | | | |
| TOT FIXTURES | 3 | \$2,880 | | | | | GEN | O | GENERATOR | 1 | | 0.00 | | | | |
| # UNITS | 1 | 1.00 | | | | | | | | | | | | | | |

| TOTAL RCN | 489,012 |
|----------------|------------|
| CONDITION ELEM | CD |
| EXTERIOR | F |
| INTERIOR | F |
| KITCHEN | F |
| BATHS | F |
| HEAT | O |
| ELECT | O |
| EFF.YR/AGE | 1960 / 62 |
| COND | 48 48 % |
| FUNC | 0 |
| ECON | 0 |
| DEPR | 48 % GD 52 |
| RCNLD | \$254,300 |