

Key: 3854

Town of SCITUATE - Fiscal Year 2024

10/18/2023 5:31 pm SEQ #: 3.673

LEGAL

CURRENT OWNER				PARCEL ID				LOCATION				
LOVERIN MARC 9 FIFTH AV SCITUATE, MA 02066				34-7-15-0				9 FIFTH AV				
TRANSFER HISTORY				DOS	T	SALE PRICE		BK-PG (Cert)				
LOVERIN MARC				05/10/2021	F	1 (131967)						
LOVERIN MARC & NOBLE AMIT				05/01/2018	QS	495,700 (126733)						
US BANK NATIONAL ASSOCIAT				11/20/2017	L	477,000 (126082)						
CD	T	AC/SF/UN	Ngh	Inf1	Inf2	ADJ BASE	SAF	Inf3	Lpi	VC	CREDIT AMT	ADJ VALUE
100	S	10,000	OS 1.00	100	1.00	440,000	3.58	100	1.00	R08		361,190

LAND

TOTAL	10,019 SF	ZONING	FRNT	104	ASSESSED	CURRENT	PREVIOUS
Ngh	OCEANSIDE	NOTE			LAND	361,200	328,400
Inf1	FACTOR 100		BUILDING	425,400	378,700		
Inf2	PHY 100		DETACHED	0	0		
			OTHER	0	0		
			TOTAL		786,600	707,100	

DETACHED

TY	QUAL	COND	DIM/NOTE	YB	UNITS	ADJ PRICE	RCNLD



CLASS	CLASS%	DESCRIPTION		BN ID	BN	CARD	
1010	100	SINGLE FAMILY			1	1 of 1	
PMT NO	PMT DT	TY	DESC	AMOUNT	INSP	BY	1st %
03-644	10/20/2003	2	ADDITIONS	66,000	07/27/2004	SJ	100 100
96-42	02/01/1996	2	ADDITIONS				100 100
	05/01/1986	3	ALTERATIONS				100 100
		6	CYCL GROWTH				100 100

BUILDING

BUILDING	CD	ADJ	DESC	MEASURE	4/6/2010	SJ
MODEL	1		RESIDENTIAL	LIST	4/6/2010	EST
STYLE	4	1.10	CAPE [100%]	REVIEW	9/10/2019	JD
QUALITY	A	1.00	AVERAGE [100%]			
FRAME	1	1.00	WOOD FRAME [100%]			

BLDG COMMENTS

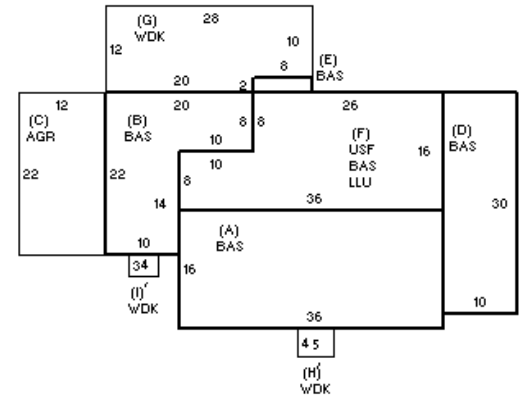

YEAR BLT	1954	SIZE ADJ	1.000
NET AREA	2,184	DETAIL ADJ	1.100
\$NLA(RCN)	\$240	OVERALL	1.000
CAPACITY		UNITS	ADJ
STORIES	1	1.00	
ROOMS	7	1.00	
BEDROOMS	4	1.00	
BATHROOMS	3	1.00	
# 1/2 BATHS	0	1.00	
TOT FIXTURES	9	\$7,920	
# UNITS	1	1.00	

ELEMENT	CD	DESCRIPTION	ADJ	S	BAT	T	DESCRIPTION	UNITS	YB	ADJ PRICE	RCN	TOTAL RCN	525,237
FOUNDATION	4	CONT BSMT WALL	1.00	+	BAS	L	BASE AREA	1,372	1954	211.24	289,825		
EXT COVER	4	VINYL	1.00	C	AGR	N	ATT GARAGE	264		53.94	14,239		
ROOF SHAPE	1	GABLE	1.00	+	BAS	L	BASE AREA	316	2004	211.24	66,753		
ROOF COVER	1	ASPH SHINGLES	1.00	F	LLU	N	LOWER LEVEL UNF	496		61.33	30,419		
FLOOR COVER	14	COMB	1.00	F	USF	L	UPPER STORY FIN	496	1954	192.10	95,283		
INT FINISH	1	PLASTER	1.00	+	WDK	N	WOOD DECK	352		38.40	13,517		
HEATING/COOLING	1	FORCED AIR	1.00	F11	O	FPL 1S 1OP		1		7,281.00	7,281		
FUEL SOURCE	1	OIL	1.00										

CONDITION ELEM	CD
EXTERIOR	G
INTERIOR	V
KITCHEN	V
BATHS	V
HEAT	A
ELECT	A

EFF.YR/AGE	2003 / 19	
COND	18	18 %
FUNC	0	
ECON	0	
DEPR	19	% GD 81

RCNLD	\$425,400
-------	-----------