

Key: 4009

Town of SCITUATE - Fiscal Year 2024

10/18/2023 5:31 pm SEQ #: 3.827

LEGAL

LAND

DETACHED

BUILDING

CURRENT OWNER				PARCEL ID				LOCATION			
BROOKS JOSHUA L & SUZANNE 6 LAWSON RD SCITUATE, MA 02066				38-5-18-0				6 LAWSON RD			
TRANSFER HISTORY				DOS	T	SALE PRICE	BK-PG (Cert)				
BROOKS JOSHUA L & SUZANNE				04/22/2022	QS	752,500	56721-96				
BRITTON MICHAEL & CHARLOT				12/08/1989	QS	230,000	9500-266				
VARNEY ELLEN C & ZUMBACH				07/18/1986	XX		6955-19				

CLASS	CLASS%	DESCRIPTION			BN ID	BN	CARD	
1010	100	SINGLE FAMILY				1	1 of 1	
PMT NO	PMT DT	TY	DESC	AMOUNT	INSP	BY	1st	%
23-301	04/05/2023	6	CYCL GROWTH		07/19/2023	JD	25	25
		3	ALTERATIONS	60,300	06/02/2023	NC	100	0
		7	OTHERS		09/06/2022	JD	100	100
E22-0443	06/02/2022	3	ALTERATIONS	6,500	06/02/2023	NC	100	100
88-216	05/01/1988	2	ADDITIONS				100	100

TOTAL	29,000 SF	ZONING	FRNT	119	ASSESSED	CURRENT	PREVIOUS
Ngh	SCITUATE	NOTE			LAND	351,100	336,900
Inf1	FACTOR 100		BUILDING	392,300	329,500		
Inf2	PHY 100		DETACHED	0	0		
			OTHER	0	0		
			TOTAL		743,400	666,400	

TY	QUAL	COND	DIM/NOTE	YB	UNITS	ADJ PRICE	RCNLD

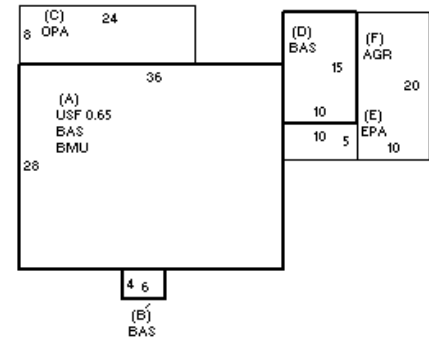

BUILDING	CD	ADJ	DESC	MEASURE	7/19/2023	JD
MODEL	1		RESIDENTIAL	LIST	7/19/2023	EST
STYLE	4	1.10	CAPE [100%]	REVIEW	7/5/2023	MR
QUALITY	+	1.10	AVG +/GOOD - [100%]			
FRAME	1	1.00	WOOD FRAME [100%]			

BLDG COMMENTS
MLS

YEAR BLT	1930	SIZE ADJ	1.000	ELEMENT	CD	DESCRIPTION	ADJ	S	BAT	T	DESCRIPTION	UNITS	YB	ADJ PRICE	RCN	TOTAL RCN	544,862		
NET AREA	1,837	DETAIL ADJ	1.122	FOUNDATION	4	CONT BSMT WALL	1.00	A	BMU	N	BSMT UNFINISHED	1,008		51.73	52,142	CONDITION ELEM	CD		
\$NLA(RCN)	\$297	OVERALL	1.000	EXT COVER	1	WD SHINGLES	1.00	A	USF	L	UPPER STORY FIN	655	1930	229.97	150,632	EXTERIOR	A		
				ROOF SHAPE	1	GABLE	1.00	+	BAS	L	BASE AREA	1,182	1930	252.88	298,910	INTERIOR	A		
				ROOF COVER	1	ASPH SHINGLES	1.00	C	OPA	N	OPEN PORCH	192		56.65	10,877	KITCHEN	V		
				FLOOR COVER	2	SOFTWOOD	1.00	E	EPA	N	ENCLOSED PORCH	50		99.22	4,961	BATHS	G		
				INT FINISH	1	PLASTER	1.00	F	AGR	N	ATT GARAGE	200		66.70	13,341	HEAT	A		
				HEATING/COOLING	2	HOT WATER	1.02	F21	O	O	FPL 2S 1OP	1		9,062.90	9,063	ELECT	U		
				FUEL SOURCE	1	OIL	1.00												
																		EFF.YR/AGE	1984 / 38
																		COND	26 26 %
																		FUNC	2 uc
																		ECON	0
																		DEPR	28 % GD 72
																		RCNLD	\$392,300