

Key: 4061

Town of SCITUATE - Fiscal Year 2024

10/18/2023 5:31 pm SEQ #: 3.879

LEGAL

CURRENT OWNER				PARCEL ID				LOCATION			
CLANCY MICHAEL P & SUSAN L 37 JACKSON ROAD SCITUATE, MA 02066				38-6-11-0				37 JACKSON RD			
TRANSFER HISTORY				DOS	T	SALE PRICE	BK-PG (Cert)				
CLANCY MICHAEL P & SUSAN				10/17/1997	QS	185,000	(92241)				
LUKACIK JOYCE W				07/22/1992	XX	100	(C00083304)				
LUKACIK ROBERT & JOYCE W				01/01/1965	XX		36252-0				

CLASS	CLASS%	DESCRIPTION			BN ID	BN	CARD	
1010	100	SINGLE FAMILY				1	1 of 1	
PMT NO	PMT DT	TY	DESC	AMOUNT	INSP	BY	1st	%
03-519	08/29/2003	2	ADDITIONS		06/21/2005	SJ	100	100
		2	ADDITIONS	5,000	08/11/2004	SJ	100	100

LAND

CD	T	AC/SF/UN	Ngh	Inf1	Inf2	ADJ BASE	SAF	Inf3	Lpi	VC	CREDIT AMT	ADJ VALUE
100	S	19,429	SC	1.00	100	1.00	100	1.00	R03	0.90		339,210

TOTAL	19,429 SF	ZONING	FRNT	117	ASSESSED	CURRENT	PREVIOUS
Ngh	SCITUATE	NOTE	LAND	339,200	325,500		
Inf1	FACTOR 100		BUILDING	328,000	309,200		
Inf2	PHY 100		DETACHED	0	0		
			OTHER	0	0		
			TOTAL	667,200	634,700		

DETACHED

TY	QUAL	COND	DIM/NOTE	YB	UNITS	ADJ PRICE	RCNLD

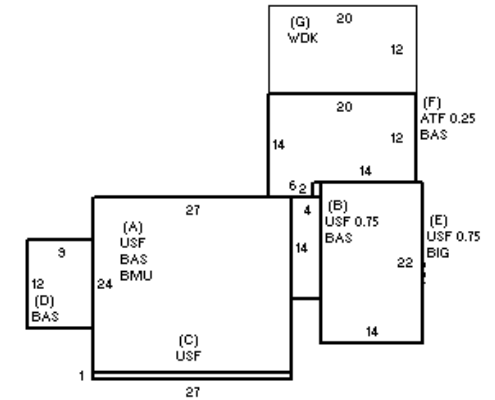

BUILDING

BUILDING	CD	ADJ	DESC	MEASURE	9/20/2010	PL
MODEL	1		RESIDENTIAL	LIST	9/20/2010	EST
STYLE	5	1.00	COLONIAL [100%]	REVIEW	4/5/2011	ER
QUALITY	A	1.00	AVERAGE [100%]			
FRAME	1	1.00	WOOD FRAME [100%]			

BLDG COMMENTS

FY12 FR-G TO AVE

G

YEAR BLT	1956	SIZE ADJ	1.000	ELEMENT	CD	DESCRIPTION	ADJ	S	BAT	T	DESCRIPTION	UNITS	YB	ADJ PRICE	RCN	TOTAL RCN	475,419													
NET AREA	2,075	DETAIL ADJ	1.020	FOUNDATION	4	CONT BSMT WALL	1.00	A	BMU	N	BSMT UNFINISHED	648		54.48	35,301															
\$NLA(RCN)	\$229	OVERALL	1.000	EXT COVER	2	CLAPBOARD	1.00	+	BAS	L	BASE AREA	1,064	1956	204.27	217,338															
				ROOF SHAPE	1	GABLE	1.00	+	USF	L	UPPER STORY FIN	948	1956	185.76	176,098															
				ROOF COVER	1	ASPH SHINGLES	1.00	E	BIG	N	BUILT-IN GARAGE	308		52.00	16,016															
				FLOOR COVER	14	COMB	1.00	F	ATF	L	ATTIC FINISH	63	1956	131.98	8,315															
				INT FINISH	1	PLASTER	1.00	G	WDK	N	WOOD DECK	240		38.40	9,216															
				HEATING/COOLING	2	HOT WATER	1.02		F21	O	FPL 2S 1OP	1		8,239.00	8,239															
				FUEL SOURCE	99	N/A	1.00																							
<table border="1"> <thead> <tr> <th>CONDITION ELEM</th> <th>CD</th> </tr> </thead> <tbody> <tr> <td>EXTERIOR</td> <td></td> </tr> <tr> <td>INTERIOR</td> <td></td> </tr> <tr> <td>KITCHEN</td> <td></td> </tr> <tr> <td>BATHS</td> <td></td> </tr> <tr> <td>HEAT</td> <td></td> </tr> <tr> <td>ELECT</td> <td></td> </tr> </tbody> </table>																CONDITION ELEM	CD	EXTERIOR		INTERIOR		KITCHEN		BATHS		HEAT		ELECT		
CONDITION ELEM	CD																													
EXTERIOR																														
INTERIOR																														
KITCHEN																														
BATHS																														
HEAT																														
ELECT																														
<table border="1"> <thead> <tr> <th>EFF.YR/AGE</th> <td colspan="2">1972 / 50</td> </tr> </thead> <tbody> <tr> <td>COND</td> <td>31</td> <td>31 %</td> </tr> <tr> <td>FUNC</td> <td>0</td> <td></td> </tr> <tr> <td>ECON</td> <td>0</td> <td></td> </tr> <tr> <td>DEPR</td> <td>31</td> <td>% GD 69</td> </tr> </tbody> </table>																EFF.YR/AGE	1972 / 50		COND	31	31 %	FUNC	0		ECON	0		DEPR	31	% GD 69
EFF.YR/AGE	1972 / 50																													
COND	31	31 %																												
FUNC	0																													
ECON	0																													
DEPR	31	% GD 69																												
<table border="1"> <thead> <tr> <th>RCNLD</th> <td>\$328,000</td> </tr> </thead> </table>																RCNLD	\$328,000													
RCNLD	\$328,000																													