

Key: 4392

Town of SCITUATE - Fiscal Year 2024

10/18/2023 5:31 pm SEQ #: 4.161

LEGALS

CURRENT OWNER				PARCEL ID				LOCATION			
RICE CHERYL A & CALLAND JAMES 78 HATHERLY RD SCITUATE, MA 02066				39-13-4-F				78 HATHERLY RD			
TRANSFER HISTORY				DOS	T	SALE PRICE	BK-PG (Cert)				
RICE CHERYL A & CALLAND J				03/17/2010	F	1	38332-202				
RICE CHERYL A & CALLAND J				05/19/2009	F	1	37219-116				
RICE CHERYL A				04/05/2004	A	355,000	27886-55				

CLASS	CLASS%	DESCRIPTION			BN ID	BN	CARD	
1010	100	SINGLE FAMILY				1	1 of 1	
PMT NO	PMT DT	TY	DESC	AMOUNT	INSP	BY	1st	%
21-1036	07/16/2021	3	ALTERATIONS	13,500	07/14/2022	JD	100	100
10-466	09/30/2010	3	ALTERATIONS	12,000	07/11/2011	SJ	100	100
93-176	04/01/1993	3	ALTERATIONS				100	100
		7	OTHERS				100	100

LAND

CD	T	AC/SF/UN	Ngh	Inf1	Inf2	ADJ BASE	SAF	Inf3	Lpi	VC	CREDIT AMT	ADJ VALUE	
100	S	9,500 OS	1.00	100	1.00	100	1.00	440,000	3.75	100	1.00	R02 1.00	360,200

TOTAL	9,500 SF		ZONING	FRNT	197		ASSESSED	CURRENT	PREVIOUS
Ngh	OCEANSIDE		NOTE			LAND	360,200	327,500	
Inf1	FACTOR 100			BUILDING	213,300	189,800			
Inf2	PHY 100			DETACHED	600	600			
				OTHER	0	0			
				<b>TOTAL</b>	<b>574,100</b>	<b>517,900</b>			

DETACHED

TY	QUAL	COND	DIM/NOTE	YB	UNITS	ADJ PRICE	RCNLD	PHOTO
SHF	A	1.00 30 0.70	9 X 6		54	17.03	600	07/14/2022

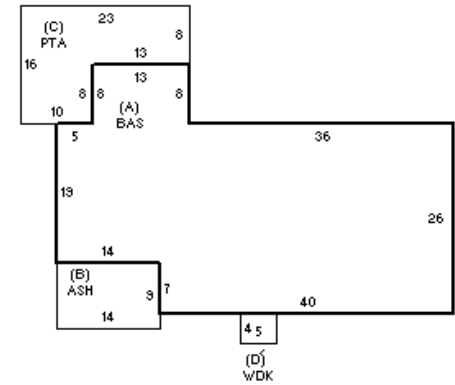

BUILDING	CD	ADJ	DESC	MEASURE	7/14/2022	JD
MODEL	1		RESIDENTIAL	LIST	7/14/2022	EST
STYLE	1	0.85	RANCH [100%]	REVIEW	4/1/2011	ER
QUALITY	A	1.00	AVERAGE [100%]			
FRAME	1	1.00	WOOD FRAME [100%]			

BUILDING

YEAR BLT	1960	SIZE ADJ	1.000	ELEMENT	CD	DESCRIPTION	ADJ	S	BAT	T	DESCRIPTION	UNITS	YB	ADJ PRICE	RCN	TOTAL RCN	288,260															
NET AREA	1,410	DETAIL ADJ	0.884	FOUNDATION	3	CONT WALL	1.00	A	BAS	L	BASE AREA	1,410	1960	191.94	270,632																	
\$NLA(RCN)	\$204	OVERALL	1.000	EXT COVER	1	WD SHINGLES	1.00	B	ASH	N	ATT SHED	126		22.35	2,816																	
				ROOF SHAPE	1	GABLE	1.00	C	PTA	N	PATIO	264		14.90	3,934																	
				ROOF COVER	1	ASPH SHINGLES	1.00	D	WDK	N	WOOD DECK	20		38.40	768																	
				FLOOR COVER	34	COMB	1.00	F11	O	FPL 1S 10P	1		7,281.00	7,281																		
				INT FINISH	1	PLASTER	1.00																									
				HEATING/COOLING	11	HW/COOL AIR	1.04																									
				FUEL SOURCE	2	GAS	1.00																									
				<table border="1"> <thead> <tr> <th>CONDITION ELEM</th> <th>CD</th> </tr> </thead> <tbody> <tr> <td>EXTERIOR</td> <td>G</td> </tr> <tr> <td>INTERIOR</td> <td>G</td> </tr> <tr> <td>KITCHEN</td> <td>G</td> </tr> <tr> <td>BATHS</td> <td>V</td> </tr> <tr> <td>HEAT</td> <td>A</td> </tr> <tr> <td>ELECT</td> <td>A</td> </tr> </tbody> </table>														CONDITION ELEM	CD	EXTERIOR	G	INTERIOR	G	KITCHEN	G	BATHS	V	HEAT	A	ELECT	A	
CONDITION ELEM	CD																															
EXTERIOR	G																															
INTERIOR	G																															
KITCHEN	G																															
BATHS	V																															
HEAT	A																															
ELECT	A																															
				<table border="1"> <thead> <tr> <th>EFF.YR/AGE</th> <td colspan="2">1984 / 38</td> </tr> </thead> <tbody> <tr> <td>COND</td> <td>26</td> <td>26 %</td> </tr> <tr> <td>FUNC</td> <td>0</td> <td></td> </tr> <tr> <td>ECON</td> <td>0</td> <td></td> </tr> <tr> <td>DEPR</td> <td>26</td> <td>% GD 74</td> </tr> </tbody> </table>														EFF.YR/AGE	1984 / 38		COND	26	26 %	FUNC	0		ECON	0		DEPR	26	% GD 74
EFF.YR/AGE	1984 / 38																															
COND	26	26 %																														
FUNC	0																															
ECON	0																															
DEPR	26	% GD 74																														
				<table border="1"> <thead> <tr> <th>RCNLD</th> <td>\$213,300</td> </tr> </thead> </table>														RCNLD	\$213,300													
RCNLD	\$213,300																															

G