

Key: 4454

Town of SCITUATE - Fiscal Year 2024

10/18/2023 5:31 pm SEQ #: 4.221

LEGAL LAND

CURRENT OWNER				PARCEL ID				LOCATION				
COGGINS ERIK SEBASTIAN & STEPHANIE MICHELLE				39-21-4-0				7 MAPLE AV				
15 BOWER ROAD F5 QUINCY, MA 02169				TRANSFER HISTORY				DOS	T	SALE PRICE	BK-PG (Cert)	
				COGGINS ERIK SEBASTIAN & FILII MARIA BUILDERS LLC				10/28/2019	QS	705,000	51856-172	
				GULMAN MAX				06/28/2017	O	220,000	48597-157	
								07/27/2015	H	1	45843-180	

CLASS	CLASS%	DESCRIPTION			BN ID	BN	CARD	
1010	100	SINGLE FAMILY				1	1 of 1	
PMT NO	PMT DT	TY	DESC	AMOUNT	INSP	BY	1st	%
17-664	10/17/2017	1	NEW CONST	260,000	05/15/2018	JD	100	70
17-664	10/17/2017	1	NEW CONST	260,000	12/19/2018	JD	100	100
17-617	09/19/2017	4	DEMO	8,000	05/15/2018	JD	100	100

LAND

CD	T	AC/SF/UN	Ngh	Inf1	Inf2	ADJ BASE	SAF	Inf3	Lpi	VC	CREDIT AMT	ADJ VALUE	
100	S	10,000	OS 1.00	100	1.00	100	1.00	440,000	3.58	100	1.00	R03 1.00	361,190

DETACHED

TOTAL	10,000 SF	ZONING	FRNT	230	ASSESSED	CURRENT	PREVIOUS
Ngh	OCEANSIDE	NOTE			LAND	361,200	328,400
Inf1	FACTOR 100		BUILDING	674,700	632,900		
Inf2	PHY 100		DETACHED	0	0		
			OTHER	0	0		
			TOTAL		1,035,900	961,300	

BUILDING

TY	QUAL	COND	DIM/NOTE	YB	UNITS	ADJ PRICE	RCNLD

PHOTO 04/25/2019



BLDG COMMENTS

BUILDING	CD	ADJ	DESC	MEASURE	5/15/2018	JD
MODEL	1		RESIDENTIAL	LIST	12/19/2018	JD
STYLE	5	1.00	COLONIAL [100%]	REVIEW	9/8/2020	MLS
QUALITY	G	1.20	GOOD [100%]			
FRAME	1	1.00	WOOD FRAME [100%]			

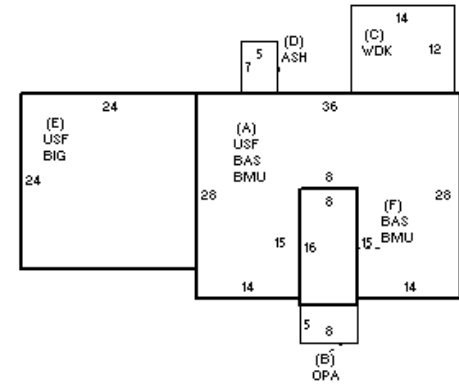

YEAR BLT	2018	SIZE ADJ	1.000
NET AREA	2,480	DETAIL ADJ	1.050
\$NLA(RCN)	\$280	OVERALL	1.000

CAPACITY	UNITS	ADJ
STORIES	2	1.00
ROOMS	7	1.00
BEDROOMS	4	1.00
BATHROOMS	2	1.00
# 1/2 BATHS	1	1.00
TOT FIXTURES	8	\$8,064
# UNITS	2	1.02

ELEMENT	CD	DESCRIPTION	ADJ
FOUNDATION	4	CONT BSMT WALL	1.00
EXT COVER	4	VINYL	1.00
ROOF SHAPE	1	GABLE	1.00
ROOF COVER	1	ASPH SHINGLES	1.00
FLOOR COVER	1	HARDWOOD	1.00
INT FINISH	2	DRYWALL	1.00
HEATING/COOLING	9	WARM/COOL AIR	1.03
FUEL SOURCE	2	GAS	1.00

S	BAT	T	DESCRIPTION	UNITS	YB	ADJ PRICE	RCN
+	BMU	N	BSMT UNFINISHED	1,016		56.33	57,232
+	BAS	L	BASE AREA	1,016	2018	244.89	248,809
A	USF	L	UPPER STORY FIN	888	2108	222.70	197,759
B	OPA	N	OPEN PORCH	40		61.80	2,472
C	WDK	N	WOOD DECK	168		46.08	7,741
D	ASH	N	ATT SHED	35		26.81	938
E	BIG	N	BUILT-IN GARAGE	576		53.73	30,950
E	USF	L	UPPER STORY FIN	576	2018	222.70	128,276
	GFP	O	GAS FIREPLACE	2		6,667.80	13,336

TOTAL RCN	695,578
CONDITION ELEM	CD
EXTERIOR	A
INTERIOR	A
KITCHEN	A
BATHS	A
HEAT	A
ELECT	A

EFF.YR/AGE	2019 / 3
COND	3 3 %
FUNC	0
ECON	0
DEPR	3 % GD 97

RCNLD	\$674,700
-------	-----------