

Key: 4502

Town of SCITUATE - Fiscal Year 2024

10/18/2023 5:31 pm SEQ #: 4.266

LEGALS

CURRENT OWNER				PARCEL ID				LOCATION			
CHASE JAMES O & DONNA 53 SCITUATE AVENUE SCITUATE, MA 02066				40-7-8-0				53 SCITUATE AV			
TRANSFER HISTORY				DOS	T	SALE PRICE	BK-PG (Cert)				
CHASE JAMES O & DONNA				10/02/1996	QS	1	14694-94				
CHASE JAMES O				06/29/1994	QS	167,500	12981-112				
FARQUHAR STEPHEN J AND OB				06/24/1983	XX		5383-357				

CLASS	CLASS%	DESCRIPTION			BN ID	BN	CARD
1010	100	SINGLE FAMILY				1	1 of 1
PMT NO	PMT DT	TY	DESC	AMOUNT	INSP	BY	1st %
97-481	08/18/1997	3	ALTERATIONS				100 100
97-197	04/30/1997	3	ALTERATIONS				100 100
93-136	03/31/1993	3	ALTERATIONS				100 100
89-545	09/27/1989	2	ADDITIONS				100 100
89-113	03/29/1989	3	ALTERATIONS				100 100

LAND

CD	T	AC/SF/UN	Ngh	Inf1	Inf2	ADJ BASE	SAF	Inf3	Lpi	VC	CREDIT AMT	ADJ VALUE	
100	S	6,159	OS 1.00	100	1.00	100	1.00	440,000	5.67	100	1.00	R03 1.00	352,660

TOTAL	6,142 SF	ZONING	FRNT	71	ASSESSED	CURRENT	PREVIOUS
Ngh	OCEANSIDE	NOTE	LAND	352,700	320,600		
Inf1	FACTOR 100		BUILDING	171,900	161,400		
Inf2	PHY 100		DETACHED	5,900	5,600		
			OTHER	0	0		
			TOTAL	530,500	487,600		

DETACHED

TY	QUAL	COND	DIM/NOTE	YB	UNITS	ADJ PRICE	RCNLD
DGF	A	1.00	70 0.30		400	49.28	5,900

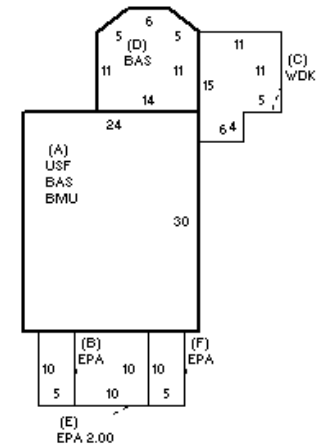

BUILDING

BUILDING	CD	ADJ	DESC	MEASURE	6/11/2009	PL
MODEL	1		RESIDENTIAL	LIST	6/11/2009	EST
STYLE	7	1.20	CONVENTIONAL [100%]	REVIEW	4/1/2011	ER
QUALITY	A	1.00	AVERAGE [100%]			
FRAME	1	1.00	WOOD FRAME [100%]			

BLDG COMMENTS

INDING

YEAR BLT	1930	SIZE ADJ	1.000	ELEMENT	CD	DESCRIPTION	ADJ	S	BAT	T	DESCRIPTION	UNITS	YB	ADJ PRICE	RCN	TOTAL RCN	477,457														
NET AREA	1,624	DETAIL ADJ	1.200	FOUNDATION	4	CONT BSMT WALL	1.00	A	BMU	N	BSMT UNFINISHED	720		52.37	37,708																
\$NLA(RCN)	\$294	OVERALL	1.000	EXT COVER	2	CLAPBOARD	1.00	A	USF	L	UPPER STORY FIN	720	1930	229.35	165,132																
				ROOF SHAPE	1	GABLE	1.00	+	EPA	N	ENCLOSED PORCH	300		90.20	27,060																
				ROOF COVER	1	ASPH SHINGLES	1.00	C	WDK	N	WOOD DECK	145		38.40	5,568																
				FLOOR COVER	2	SOFTWOOD	1.00	+	BAS	L	BASE AREA	904	1930	252.20	227,990																
				INT FINISH	1	PLASTER	1.00	F21	O	O	FPL 2S 1OP	1		8,239.00	8,239																
				HEATING/COOLING	1	FORCED AIR	1.00																								
				FUEL SOURCE	99	N/A	1.00																								
				<table border="1"> <thead> <tr> <th>CONDITION ELEM</th> <th>CD</th> </tr> </thead> <tbody> <tr> <td>EXTERIOR</td> <td></td> </tr> <tr> <td>INTERIOR</td> <td></td> </tr> <tr> <td>KITCHEN</td> <td></td> </tr> <tr> <td>BATHS</td> <td></td> </tr> <tr> <td>HEAT</td> <td></td> </tr> <tr> <td>ELECT</td> <td></td> </tr> </tbody> </table>														CONDITION ELEM	CD	EXTERIOR		INTERIOR		KITCHEN		BATHS		HEAT		ELECT	
CONDITION ELEM	CD																														
EXTERIOR																															
INTERIOR																															
KITCHEN																															
BATHS																															
HEAT																															
ELECT																															
				<table border="1"> <thead> <tr> <th>EFF.YR/AGE</th> <td>1952 / 70</td> </tr> </thead> <tbody> <tr> <td>COND</td> <td>64 64 %</td> </tr> <tr> <td>FUNC</td> <td>0</td> </tr> <tr> <td>ECON</td> <td>0</td> </tr> <tr> <td>DEPR</td> <td>64 % GD 36</td> </tr> </tbody> </table>														EFF.YR/AGE	1952 / 70	COND	64 64 %	FUNC	0	ECON	0	DEPR	64 % GD 36				
EFF.YR/AGE	1952 / 70																														
COND	64 64 %																														
FUNC	0																														
ECON	0																														
DEPR	64 % GD 36																														
				<table border="1"> <thead> <tr> <th>RCNLD</th> <td>\$171,900</td> </tr> </thead> </table>														RCNLD	\$171,900												
RCNLD	\$171,900																														