

Key: 4842

Town of SCITUATE - Fiscal Year 2024

10/18/2023 5:31 pm SEQ #: 4.593

LEGAL

CURRENT OWNER		PARCEL ID		LOCATION			
NYLEN KEVIN V & MICHELLE L 33 DAEDALUS CIR SCITUATE, MA 02066		44-3-13-0		33 DAEDALUS CIR			
TRANSFER HISTORY		DOS	T	SALE PRICE	BK-PG (Cert)		
NYLEN KEVIN V & MICHELLE		01/29/2021	QS	760,000	54299-299		
COLBERT CATHERINE		06/04/2020	F		52859-156		
COLBERT PAUL & CATHERINE		01/01/1975	QS		3971-661		

CLASS	CLASS%	DESCRIPTION			BN ID	BN	CARD	
1010	100	SINGLE FAMILY				1	1 of 1	
PMT NO	PMT DT	TY	DESC	AMOUNT	INSP	BY	1st	%
21-270	03/22/2021	7	OTHERS ALTERATIONS	20,000	07/18/2022	JD	100	100
		3			08/04/2021	JD	100	100

LAND

CD	T	AC/SF/UN	Ngh	Infl1	Infl2	ADJ BASE	SAF	Infl3	Lpi	VC	CREDIT AMT	ADJ VALUE
100	S	21,801	SC 1.00	100	1.00	396,000	1.73	100	1.00	R03	0.90	342,300

TOTAL	21,801 SF	ZONING	FRNT	304	ASSESSED	CURRENT	PREVIOUS
Ngh	SCITUATE	NOTE			LAND	342,300	328,500
Infl1	FACTOR 100		BUILDING	422,600	376,000		
Infl2	PHY 100		DETACHED	0	0		
			OTHER	0	0		
			TOTAL	764,900	704,500		

DETAILED

TY	QUAL	COND	DIM/NOTE	YB	UNITS	ADJ PRICE	RCNLD

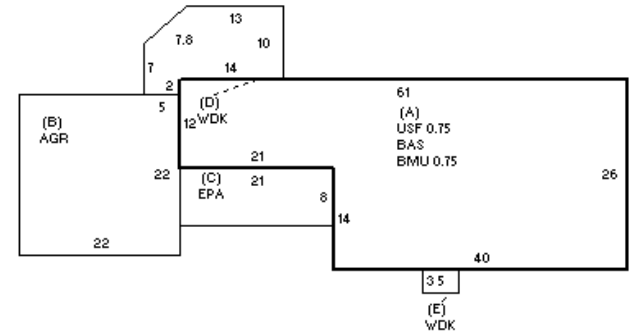

BUILDING

BUILDING	CD	ADJ	DESC	MEASURE	7/18/2022	JD
MODEL	1		RESIDENTIAL	LIST	7/18/2022	EST
STYLE	4	1.10	CAPE [100%]	REVIEW	8/4/2021	JD
QUALITY	A	1.00	AVERAGE [100%]			
FRAME	1	1.00	WOOD FRAME [100%]			

BLDG COMMENTS

MLS

LOADING

YEAR BLT	1960	SIZE ADJ	1.000	ELEMENT	CD	DESCRIPTION	ADJ	S	BAT	T	DESCRIPTION	UNITS	YB	ADJ PRICE	RCN	TOTAL RCN	586,972
NET AREA	2,261	DETAIL ADJ	1.122	FOUNDATION	4	CONT BSMT WALL	1.00	A	BMU	N	BSMT UNFINISHED	969		47.57	46,098	CONDITION ELEM	CD
\$NLA(RCN)	\$260	OVERALL	1.000	EXT COVER	1	WD SHINGLES	1.00	A	BAS	L	BASE AREA	1,292	1960	221.38	286,024	EXTERIOR	G
				ROOF SHAPE	1	GABLE	1.00	A	USF	L	UPPER STORY FIN	969	1960	201.32	195,081	INTERIOR	G
				ROOF COVER	1	ASPH SHINGLES	1.00	B	AGR	N	ATT GARAGE	484		44.45	21,515	KITCHEN	G
				FLOOR COVER	34	COMB	1.00	C	EPA	N	ENCLOSED PORCH	168		90.20	15,154	BATHS	G
				INT FINISH	1	PLASTER	1.00	+	WDK	N	WOOD DECK	200		38.40	7,680	HEAT	A
				HEATING/COOLING	2	HOT WATER	1.02	F21	O	O	FPL 2S 1OP	1		8,239.00	8,239	ELECT	A
				FUEL SOURCE	2	GAS	1.00										
CAPACITY		UNITS	ADJ														
STORIES		1.75	1.00														
ROOMS		8	1.00														
BEDROOMS		4	1.00														
BATHROOMS		2	1.00														
# 1/2 BATHS		1	1.00														
TOT FIXTURES		8	\$7,181														
# UNITS		1	1.00														
																EFF.YR/AGE	1977 / 45
																COND	28 28 %
																FUNC	0
																ECON	0
																DEPR	28 % GD 72
																RCNLD	\$422,600