

Key: 4898

Town of SCITUATE - Fiscal Year 2024

10/18/2023 5:31 pm SEQ #: 4.650

LEGALS

CURRENT OWNER				PARCEL ID				LOCATION			
MAGLIOZZI ANTHONY & JACQUELINE LEE 250 FIRST PARISH RD SCITUATE, MA 02066				44-1-1-0				250 FIRST PARISH RD			
TRANSFER HISTORY				DOS	T	SALE PRICE		BK-PG (Cert)			
MAGLIOZZI ANTHONY & CAMERON STEPHEN CLARK & COUTURE BARRY L & KATIE				01/13/2021	QS	610,000 (131402)					
				08/15/2018	QS	494,000 (127317)					
				09/09/2015	QS	459,200 (122401)					

CLASS	CLASS%	DESCRIPTION		BN ID	BN	CARD	
1010	100	SINGLE FAMILY			1	1 of 1	
PMT NO	PMT DT	TY	DESC	AMOUNT	INSP	BY	1st %
23-0474	06/06/2023	1	NEW CONST	56,000			0 0
		2	ADDITIONS		02/02/2022	JD	100 100
09-566	11/24/2009	3	ALTERATIONS	30,000	08/26/2010	SJ	100 100
09-414	09/10/2009	3	ALTERATIONS	15,000	08/26/2010	SJ	100 100
91-88	03/01/1991	3	ALTERATIONS				100 100

LAND

CD	T	AC/SF/UN	Ngh	Infl1	Infl2	ADJ BASE	SAF	Infl3	Lpi	VC	CREDIT AMT	ADJ VALUE				
100	S	40,000	SC	1.00	100	1.00	100	1.00	396,000	1.00	100	1.00	R02	0.90		363,640
300	A	0.132	SC	1.00	100	1.00	100	1.00	17,820	1.00	100	1.00	R02	0.90		2,350

DETAILED

TOTAL	1.050 Acres		ZONING	FRNT	126		ASSESSED	CURRENT	PREVIOUS
Ngh	SCITUATE		NOTE			LAND	366,000	351,300	
Infl1	FACTOR 100			BUILDING	248,500	221,200			
Infl2	PHY 100			DETACHED	1,800	1,700			
				OTHER	0	0			
					TOTAL	616,300	574,200		

TY	QUAL	COND	DIM/NOTE	YB	UNITS	ADJ PRICE	RCNLD	PHOTO
SHF	G	1.20	10 0.90	10 X 12		120	16.71	1,800

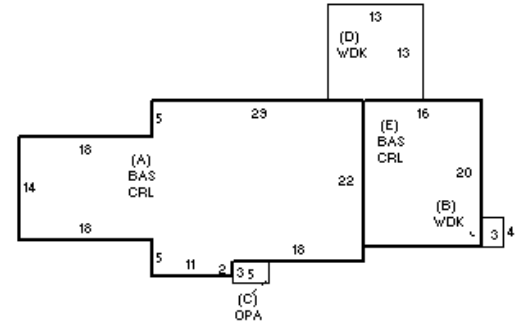

BUILDING

BUILDING	CD	ADJ	DESC	MEASURE	2/2/2022	JD
MODEL	1		RESIDENTIAL	LIST	8/12/2019	EST
STYLE	1	0.85	RANCH [100%]	REVIEW	3/29/2011	ER
QUALITY	A	1.00	AVERAGE [100%]			
FRAME	1	1.00	WOOD FRAME [100%]			

YEAR BLT	1954	SIZE ADJ	1.000
NET AREA	1,232	DETAIL ADJ	0.884
\$NLA(RCN)	\$224	OVERALL	1.000

ELEMENT	CD	DESCRIPTION	ADJ	S	BAT	T	DESCRIPTION	UNITS	YB	ADJ PRICE	RCN
FOUNDATION	3	CONT WALL	1.00	+	CRL	N	BSMT CRAWL	1,232		9.96	12,276
EXT COVER	1	WD SHINGLES	1.00	A	BAS	L	BASE AREA	912	1954	198.65	181,165
ROOF SHAPE	1	GABLE	1.00	+	WDK	N	WOOD DECK	181		38.40	6,950
ROOF COVER	1	ASPH SHINGLES	1.00	C	OPA	N	OPEN PORCH	15		51.53	773
FLOOR COVER	14	COMB	1.00	E	BAS	L	BASE AREA	320	2010	198.65	63,567
INT FINISH	2	DRYWALL	1.00		FPL	O	FIREPLACE	1		7,813.00	7,813
HEATING/COOLING	11	HW/COOL AIR	1.04								
FUEL SOURCE	2	GAS	1.00								

TOTAL RCN	276,080	
CONDITION ELEM	CD	
EXTERIOR	G	
INTERIOR	G	
KITCHEN	V	
BATHS	V	
HEAT	U	
ELECT	U	
EFF.YR/AGE	2012 / 10	
COND	10	10 %
FUNC	0	
ECON	0	
DEPR	10	% GD 90
RCNLD	\$248,500	