

Key: 5043

Town of SCITUATE - Fiscal Year 2024

10/18/2023 5:31 pm SEQ #: 4.792

LEG
AL
LAND

CURRENT OWNER				PARCEL ID				LOCATION				
CASEY WILLIAM L & NICOLE M 147 WOODLAND RD SCITUATE, MA 02066				33-7-72-0				147 WOODLAND RD				
TRANSFER HISTORY				DOS	T	SALE PRICE	BK-PG (Cert)					
CASEY WILLIAM L & NICOLE				09/24/2020	QS	885,000	(130815)					
RYAN KEVIN M & JENNIFER C				08/03/2004	QS	534,900	(105843)					
SHAW GEORGE F & RITA A				01/01/1978	QS		57802-					
CD	T	AC/SF/UN	Ngh	Inf1	Inf2	ADJ BASE	SAF	Inf3	Lpi	VC	CREDIT AMT	ADJ VALUE
100	S	20,000	SC 1.00	100	1.00	396,000	1.87	100	1.00	R04	0.90	339,960

CLASS	CLASS%	DESCRIPTION			BN ID	BN	CARD	
1010	100	SINGLE FAMILY				1	1 of 1	
PMT NO	PMT DT	TY	DESC	AMOUNT	INSP	BY	1st	%
15-33	01/20/2015	2	ADDITIONS	215,000	07/22/2015	SJ	100	10
15-33	01/20/2015	2	ADDITIONS	215,000	06/30/2016	SJ	100	90
15-33	01/20/2015	2	ADDITIONS	215,000	07/11/2017	SJ	100	100
90-123	04/05/1990	3	ALTERATIONS				100	100

DE
T
A
C
H
E
D

TOTAL	20,000 SF	ZONING	FRNT	289	ASSESSED	CURRENT	PREVIOUS
Ngh	SCITUATE	NOTE			LAND	340,000	326,200
Inf1	FACTOR 100		BUILDING	597,900	555,700		
Inf2	PHY 100		DETACHED	4,300	4,000		
			OTHER	0	0		
			TOTAL	942,200	885,900		

B
U
I
L
D
I
N
G

TY	QUAL	COND	DIM/NOTE	YB	UNITS	ADJ PRICE	RCNLD
SHF	A	1.00	10 0.90	2016	96	14.95	1,300
PTD	A	1.00	10 0.90		450	7.37	3,000

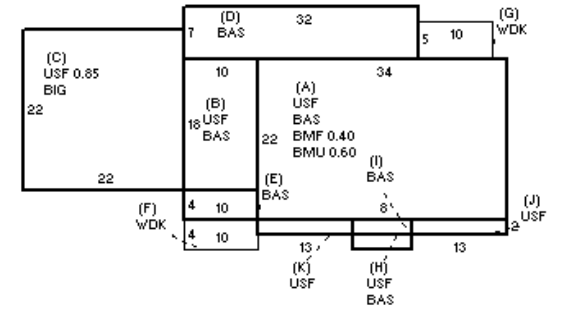

BLDG COMMENTS

MLS

Y
E
A
R
B
L
T

BUILDING	CD	ADJ	DESC	MEASURE	6/30/2016	SJ
MODEL	1		RESIDENTIAL	LIST	6/30/2016	EST
STYLE	5	1.00	COLONIAL [100%]	REVIEW	10/5/2020	JD
QUALITY	+	1.10	AVG +/GOOD - [100%]			
FRAME	1	1.00	WOOD FRAME [100%]			

YEAR BLT	1963	SIZE ADJ	1.000	ELEMENT	CD	DESCRIPTION	ADJ	S	BAT	T	DESCRIPTION	UNITS	YB	ADJ PRICE	RCN	TOTAL RCN	657,063
NET AREA	2,631	DETAIL ADJ	1.040	FOUNDATION	4	CONT BSMT WALL	1.00	A	BMU	N	BSMT UNFINISHED	449		56.87	25,534	CONDITION ELEM	CD
\$NLA(RCN)	\$250	OVERALL	1.000	EXT COVER	1	WD SHINGLES	1.00	A	BMF	N	BSMT FINISH-SEP	299		79.83	23,870	EXTERIOR	V
				ROOF SHAPE	1	GABLE	1.00	+	BAS	L	BASE AREA	1,224	1963	220.42	269,789	INTERIOR	V
				ROOF COVER	1	ASPH SHINGLES	1.00	C	BIG	N	BUILT-IN GARAGE	484		50.85	24,614	KITCHEN	V
				FLOOR COVER	34	COMB	1.00	+	WDK	N	WOOD DECK	90		42.24	3,802	BATHS	V
				INT FINISH	1	PLASTER	1.00	+	USF	L	UPPER STORY FIN	1,407	1963	200.44	282,026	HEAT	U
				HEATING/COOLING	11	HW/COOL AIR	1.04	F21	O	FPL 2S 1OP	1			9,062.90	9,063	ELECT	U
				FUEL SOURCE	2	GAS	1.00	FPL	O	FIREPLACE	1			8,594.30	8,594		
								ODS	O	OUT DOOR SHOWER	1			1,534.50	1,535		

EFF. YR/AGE	2013 / 9
COND	9 9 %
FUNC	0
ECON	0
DEPR	9 % GD 91
RCNLD	\$597,900