

Key: 506

Town of SCITUATE - Fiscal Year 2024

10/18/2023 5:31 pm SEQ #: 450

LEGAL

LAND

CURRENT OWNER				PARCEL ID				LOCATION			
GREEN ROBERT T JR & JUDITH F P.O. BOX 126 SCITUATE, MA 02066				36-1-13-0				85 MAPLE ST			
TRANSFER HISTORY				DOS	T	SALE PRICE	BK-PG (Cert)				
GREEN ROBERT T JR & JUDITH				07/30/2015	O	475,000	(122201)				
DUVAL KENNETH J				02/08/2011	QS	375,000	(115668)				
LARSON MARY PATRICIA				03/24/1989	QS		(78364)				

CLASS	CLASS%	DESCRIPTION			BN ID	BN	CARD	
1040	100	TWO FAMILY				1	1 of 1	
PMT NO	PMT DT	TY	DESC	AMOUNT	INSP	BY	1st	%
20-179	03/12/2020	2	ADDITIONS	150,000	06/29/2020	JD	100	30
20-179	03/12/2020	2	ADDITIONS	150,000	03/24/2021	JD	100	100
		4	DEMO		06/02/2016	SJ	100	100
15-687	12/16/2015	1	NEW CONST	275,000	06/02/2016	SJ	100	90
15-687	12/16/2015	1	NEW CONST	275,000	05/04/2017	SJ	100	100

CD	T	AC/SF/UN	Ngh	Inf1	Inf2	ADJ BASE	SAF	Inf3	Lpi	VC	CREDIT AMT	ADJ VALUE
100	S	40,000	WS 1.00	100	1.00	374,000	1.00	100	1.00	R03	0.85	343,430
300	A	4,082	WS 1.00	100	1.00	8,415	1.00	W50	0.50	R03	0.85	34,350

TOTAL	5.000 Acres	ZONING	FRNT	0	ASSESSED	CURRENT	PREVIOUS
Ngh	W. SCITUATE	N O T E	. PROBATE. NO.85D-0102-FM. . was 87 Maple St		LAND	377,800	345,200
Inf1	FACTOR 100		BUILDING	1,019,700	916,700		
Inf2	PHY 100		DETACHED	0	0		
			OTHER	0	0		
TOTAL						1,397,500	1,261,900

TY	QUAL	COND	DIM/NOTE	YB	UNITS	ADJ PRICE	RCNLD

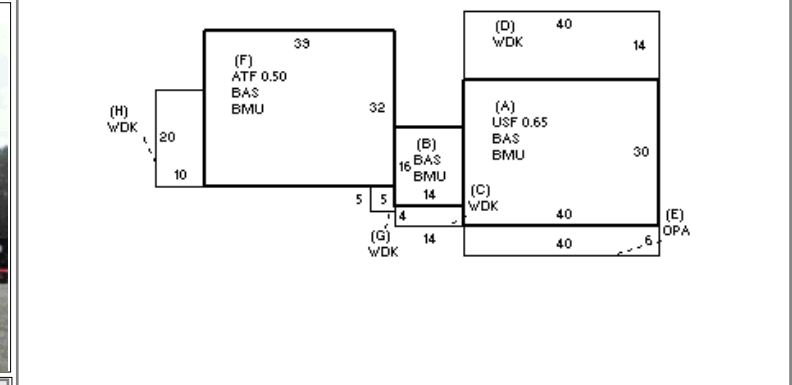

BUILDING	CD	ADJ	DESC	MEASURE	6/2/2016	SJ
MODEL	1		RESIDENTIAL	LIST	6/2/2016	SJ
STYLE	4	1.10	CAPE [100%]	REVIEW	3/24/2021	JD
QUALITY	+	1.10	AVG +/GOOD - [100%]			
FRAME	1	1.00	WOOD FRAME [100%]			

YEAR BLT	2016	SIZE ADJ	1.000
NET AREA	4,076	DETAIL ADJ	1.155
\$NLA(RCN)	\$261	OVERALL	1.000

ELEMENT	CD	DESCRIPTION	ADJ	S	BAT	T	DESCRIPTION	UNITS	YB	ADJ PRICE	RCN
FOUNDATION	4	CONT BSMT WALL	1.00	+	BMU	N	BSMT UNFINISHED	2,672		42.61	113,841
EXT COVER	1	WD SHINGLES	1.00	+	BAS	L	BASE AREA	1,424	2016	231.93	330,273
ROOF SHAPE	1	GABLE	1.00	A	USF	L	UPPER STORY FIN	780	2016	210.92	164,516
ROOF COVER	1	ASPH SHINGLES	1.00	+	WDK	N	WOOD DECK	841		42.24	35,523
FLOOR COVER	12	COMB	1.00	E	OPA	N	OPEN PORCH	240		56.65	13,596
INT FINISH	2	DRYWALL	1.00	F	BAS	L	BASE AREA	1,248	2020	231.93	289,453
HEATING/COOLING	9	WARM/COOL AIR	1.03	F	ATF	L	ATTIC FINISH	624	2020	149.85	93,509
FUEL SOURCE	1	OIL	1.00		BMG	O	BSMT GARAGE	3		2,739.73	8,219
					GEN	O	GENERATOR	1		0.00	

TOTAL RCN	1,062,144
CONDITION ELEM CD	
EXTERIOR	A
INTERIOR	A
KITCHEN	A
BATHS	A
HEAT	A
ELECT	A
EFF.YR/AGE 2018 / 4	
COND	4 4 %
FUNC	0
ECON	0
DEPR	4 % GD 96
RCNLD	\$1,019,700

DETACHED

BUILDING

G