

Key: 5089

Town of SCITUATE - Fiscal Year 2024

10/18/2023 5:31 pm SEQ #: 4.837

LEGALS

CURRENT OWNER				PARCEL ID				LOCATION			
CONLEY COLLEEN B & MATTHEWS PATRICK J 102 LAWSON RD SCITUATE, MA 02066				33-4-12-0				102 LAWSON RD			
TRANSFER HISTORY				DOS	T	SALE PRICE	BK-PG (Cert)				
CONLEY COLLEEN B & MULLEN RUTH				04/20/2021	QS	542,102	54819-6				
				09/29/1994	QS	170,000	13173-52				
GRABLE JOAN S TRUSTEE				11/30/1993	QS	164,900	12437-255				

CLASS	CLASS%	DESCRIPTION			BN ID	BN	CARD	
1010	100	SINGLE FAMILY				1	1 of 1	
PMT NO	PMT DT	TY	DESC	AMOUNT	INSP	BY	1st	%
		7	OTHERS		02/26/2021	JD	100	100

LAND

CD	T	AC/SF/UN	Ngh	Infl1	Infl2	ADJ BASE	SAF	Infl3	Lpi	VC	CREDIT AMT	ADJ VALUE
100	S	21,000	SC 1.00	100	1.00	396,000	1.79	100	1.00	R04	0.90	341,270

TOTAL	21,000 SF	ZONING	NOTED	FRNT	140	ASSESSED	CURRENT	PREVIOUS
Ngh	SCITUATE			LAND		341,300	327,500	
Infl1	FACTOR 100			BUILDING		221,100	196,600	
Infl2	PHY 100			DETACHED		0	0	
				OTHER		0	0	
				TOTAL		562,400	524,100	

DETACHED

TY	QUAL	COND	DIM/NOTE	YB	UNITS	ADJ PRICE	RCNLD

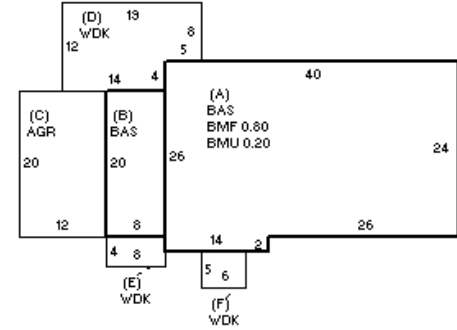

BUILDING

BUILDING	CD	ADJ	DESC	MEASURE	6/30/2022	JD
MODEL	1		RESIDENTIAL	LIST	6/30/2022	EST
STYLE	1	0.85	RANCH [100%]	REVIEW	2/26/2021	JD
QUALITY	A	1.00	AVERAGE [100%]			
FRAME	1	1.00	WOOD FRAME [100%]			

BLDG COMMENTS	MLS
---------------	-----

G

YEAR BLT	1956	SIZE ADJ	1.000	ELEMENT	CD	DESCRIPTION	ADJ	S	BAT	T	DESCRIPTION	UNITS	YB	ADJ PRICE	RCN	TOTAL RCN	325,219		
NET AREA	1,148	DETAIL ADJ	0.875	FOUNDATION	4	CONT BSMT WALL	1.00	A	BMU	N	BSMT UNFINISHED	198		47.32	9,369	CONDITION ELEM	CD		
\$NLA(RCN)	\$283	OVERALL	1.000	EXT COVER	1	WD SHINGLES	1.00	A	BMF	N	BSMT FINISH-SEP	790		66.43	52,478	EXTERIOR	G		
				ROOF SHAPE	1	GABLE	1.00	+	BAS	L	BASE AREA	1,148	1956	200.50	230,171	INTERIOR	G		
				ROOF COVER	1	ASPH SHINGLES	1.00	C	AGR	N	ATT GARAGE	240		56.05	13,452	KITCHEN	A		
				FLOOR COVER	14	COMB	1.00	+	WDK	N	WOOD DECK	270		38.40	10,368	BATHS	A		
				INT FINISH	1	PLASTER	1.00	F11	O	FPL 1S 1OP	1		7,281.00	7,281	HEAT	A			
				HEATING/COOLING	9	WARM/COOL AIR	1.03								ELECT	A			
				FUEL SOURCE	2	GAS	1.00												
CAPACITY			UNITS	ADJ														TOTAL RCN	\$221,100
STORIES	1	1.00																EFF.YR/AGE	1971 / 51
ROOMS	5	1.00																COND	32 32 %
BEDROOMS	3	1.00																FUNC	0
BATHROOMS	1	1.00																ECON	0
# 1/2 BATHS	0	1.00																DEPR	32 % GD 68
TOT FIXTURES	3	\$2,100																RCNLD	
# UNITS	1	1.00																	