

Key: 5121

Town of SCITUATE - Fiscal Year 2024

10/18/2023 5:31 pm SEQ #: 4.867

LEGAL

LAND

DETACHED

BUILDING

CURRENT OWNER				PARCEL ID				LOCATION			
MCGUINNESS MARK F & JANE 15 MANOR ROAD SCITUATE, MA 02066				33-5-4-0				15 MANOR RD			
TRANSFER HISTORY				DOS	T	SALE PRICE	BK-PG (Cert)				
MCGUINNESS MARK F & JANE				04/01/1983	QS	97,000	5327-493				
REED WALTER D AND MARGARE				01/01/1973	XX		3805-113				
DUFFY EDWARD L AND CATHER				01/01/1967	XX		3304-240				

CLASS	CLASS%	DESCRIPTION			BN ID	BN	CARD	
1010	100	SINGLE FAMILY				1	1 of 1	
PMT NO	PMT DT	TY	DESC	AMOUNT	INSP	BY	1st	%
07-632	07/09/2007	3	ALTERATIONS	8,500	06/26/2008	SJ	100	100
93-423	07/19/1993	3	ALTERATIONS				100	100
90-555	09/18/1990	3	ALTERATIONS				100	100

CD	T	AC/SF/UN	Ngh	Infl1	Infl2	ADJ BASE	SAF	Infl3	Lpi	VC	CREDIT AMT	ADJ VALUE
100	S	40,000	SC 1.00	100	1.00	396,000	1.00	100	1.00	R03	0.90	363,640
300	A	0.142	SC 1.00	100	1.00	17,820	1.00	100	1.00	R03	0.90	2,530

TOTAL	1.060 Acres		ZONING	FRNT	161	ASSESSED	CURRENT	PREVIOUS
Ngh	SCITUATE		NOTE			LAND	366,200	351,500
Infl1	FACTOR 100			BUILDING	350,200	316,000		
Infl2	PHY 100			DETACHED	6,800	6,500		
				OTHER	0	0		
						TOTAL	723,200	674,000

TY	QUAL	COND	DIM/NOTE	YB	UNITS	ADJ PRICE	RCNLD
GHD	V	1.50	10 0.90	12 X 16	2007	192	36.38
SHF	A	1.00	30 0.70			40	17.03

PHOTO 10/29/2003

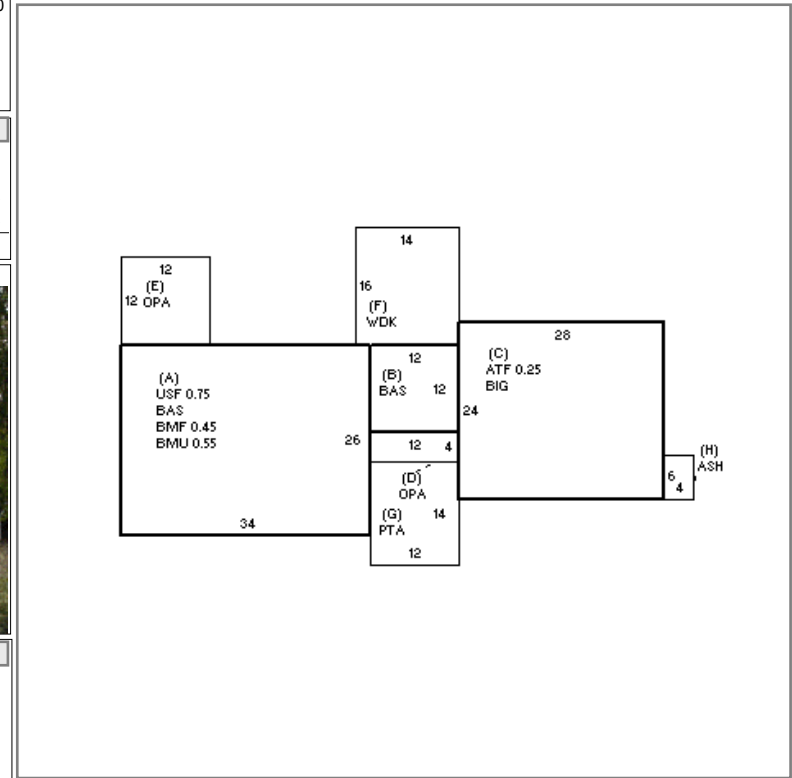

BUILDING	CD	ADJ	DESC	MEASURE	3/14/2011	PL
MODEL	1		RESIDENTIAL	LIST	3/14/2011	EST
STYLE	4	1.10	CAPE [100%]	REVIEW	3/28/2011	ER
QUALITY	A	1.00	AVERAGE [100%]			
FRAME	1	1.00	WOOD FRAME [100%]			

YEAR BLT	1958	SIZE ADJ	1.000
NET AREA	1,859	DETAIL ADJ	1.100
\$NLA(RCN)	\$273	OVERALL	1.000

ELEMENT	CD	DESCRIPTION	ADJ	S	BAT	T	DESCRIPTION	UNITS	YB	ADJ PRICE	RCN
FOUNDATION	4	CONT BSMT WALL	1.00	A	BMU	N	BSMT UNFINISHED	486		48.92	23,775
EXT COVER	1	WD SHINGLES	1.00	A	BMF	N	BSMT FINISH-SEP	398		68.67	27,332
ROOF SHAPE	1	GABLE	1.00	A	USF	L	UPPER STORY FIN	663	1958	204.33	135,473
ROOF COVER	1	ASPH SHINGLES	1.00	+	BAS	L	BASE AREA	1,028	1958	224.69	230,983
FLOOR COVER	14	COMB	1.00	C	BIG	N	BUILT-IN GARAGE	672		45.40	30,512
INT FINISH	1	PLASTER	1.00	C	ATF	L	ATTIC FINISH	168	1958	145.17	24,389
HEATING/COOLING	1	FORCED AIR	1.00	+	OPA	N	OPEN PORCH	192		51.50	9,888
FUEL SOURCE	99	N/A	1.00	F	WDK	N	WOOD DECK	224		38.40	8,602
				G	PTA	N	PATIO	168		14.90	2,503
				H	ASH	N	ATT SHED	24		22.33	536
				F21	O	FPL 2S 1OP		1		8,239.00	8,239
				GEN	O	GENERATOR		1		0.00	

TOTAL RCN	507,512	
CONDITION ELEM	CD	
EXTERIOR		
INTERIOR		
KITCHEN		
BATHS		
HEAT		
ELECT		
EFF.YR/AGE	1972 / 50	
COND	31	31 %
FUNC	0	
ECON	0	
DEPR	31	% GD 69
RCNLD	\$350,200	