

Key: 514

Town of SCITUATE - Fiscal Year 2024

10/18/2023 5:31 pm SEQ #: 458

LEGAL

LAND

CURRENT OWNER				PARCEL ID				LOCATION			
CRIMMINS MICHAEL 16 MAPLE STREET SCITUATE, MA 02066				36-2-4-F				16 MAPLE ST			
TRANSFER HISTORY				DOS	T	SALE PRICE	BK-PG (Cert)				
CRIMMINS MICHAEL				02/21/1996	QS	284,900	14150-215				
REGA PATRICK JR & BETTE				01/01/1968	XX		3387-8				
ROBINSON ANN LURETA ET AL				01/01/1963	XX		2937-17				

CLASS	CLASS%	DESCRIPTION			BN ID	BN	CARD	
1040	100	TWO FAMILY				1	1 of 1	
PMT NO	PMT DT	TY	DESC	AMOUNT	INSP	BY	1st	%
22-0188	02/24/2022	3	ALTERATIONS	12,608	08/04/2022	JD	100	100
12-474	08/13/2012	3	ALTERATIONS	10,505	07/29/2013	SJ	100	100
07-091	03/01/2007	2	ADDITIONS	1,800			100	100
		6	CYCL GROWTH				100	100

CD	T	AC/SF/UN	Ngh	Inf1	Inf2	ADJ BASE	SAF	Inf3	Lpi	VC	CREDIT AMT	ADJ VALUE
100	S	40,000	WS 1.00	100	1.00	374,000	1.00	100	1.00	R03	0.85	343,430
300	A	0.034	WS 1.00	100	1.00	16,830	1.00	100	1.00	R03	0.85	570

TOTAL	41,513 SF	ZONING	FRNT	206	ASSESSED	CURRENT	PREVIOUS
Ngh	W. SCITUATE	NOTE			LAND	344,000	312,800
Inf1	FACTOR 100		BUILDING	499,100	462,700		
Inf2	PHY 100		DETACHED	0	0		
			OTHER	0	0		
TOTAL					843,100	775,500	

TY	QUAL	COND	DIM/NOTE	YB	UNITS	ADJ PRICE	RCNLD

PHOTO 08/04/2022

BLDG COMMENTS

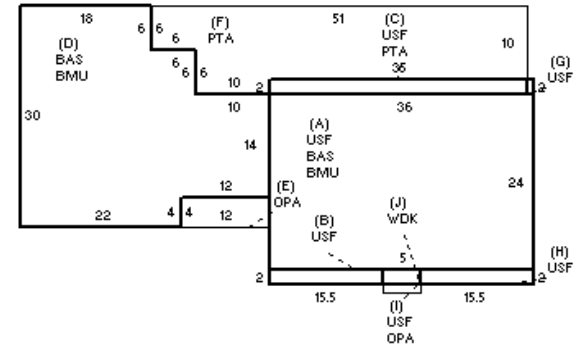

DETACHED

BU I L D I N G

BUILDING	CD	ADJ	DESC	MEASURE	8/4/2022	JD
MODEL	1		RESIDENTIAL	LIST	8/4/2022	EST
STYLE	5	1.00	COLONIAL [100%]	REVIEW	3/7/2011	KT
QUALITY	+	1.10	AVG +/GOOD - [100%]			
FRAME	1	1.00	WOOD FRAME [100%]			

YEAR BLT	1961	SIZE ADJ	1.000	ELEMENT	CD	DESCRIPTION	ADJ	S	BAT	T	DESCRIPTION	UNITS	YB	ADJ PRICE	RCN	TOTAL RCN	693,185
NET AREA	2,688	DETAIL ADJ	1.040	FOUNDATION	4	CONT BSMT WALL	1.00	+	BMU	N	BSMT UNFINISHED	1,680		45.85	77,023		
\$NLA(RCN)	\$258	OVERALL	1.000	EXT COVER	1	WD SHINGLES	1.00	+	BAS	L	BASE AREA	1,680	1961	219.69	369,083		
				ROOF SHAPE	1	GABLE	1.00	+	USF	L	UPPER STORY FIN	1,008	1961	199.79	201,385		
				ROOF COVER	1	ASPH SHINGLES	1.00	+	PTA	N	PATIO	576		16.39	9,440		
				FLOOR COVER	24	COMB	1.00	+	OPA	N	OPEN PORCH	58		56.65	3,286		
				INT FINISH	1	PLASTER	1.00	J	WDK	N	WOOD DECK	5		42.24	211		
				HEATING/COOLING	2	HOT WATER	1.02		BMG	O	BSMT GARAGE	2		2,740.10	5,480		
				FUEL SOURCE	2	GAS	1.00		F21	O	FPL 2S 1OP	2		9,062.35	18,125		
									GEN	O	GENERATOR	1		0.00			

CONDITION ELEM	CD
EXTERIOR	G
INTERIOR	G
KITCHEN	A
BATHS	A
HEAT	A
ELECT	U

EFF.YR/AGE	1977 / 45
COND	28 28 %
FUNC	0
ECON	0
DEPR	28 % GD 72
RCNLD	\$499,100