

Key: 5268

Town of SCITUATE - Fiscal Year 2024

10/18/2023 5:31 pm SEQ #: 5.014

LEGAL

LAND

DETACHED

BUILDING

CURRENT OWNER				PARCEL ID				LOCATION			
OSIER LAWRENCE P & LOIS K 2126 HASTINGS DRIVE CHARLOTTE, NC 28207				45-2-67-0				25 PORTER RD			
TRANSFER HISTORY				DOS	T	SALE PRICE		BK-PG (Cert)			
OSIER LAWRENCE P & LOIS K				03/22/2022	QS	817,000		56586-183			
DIEMER J & FORTIER R				01/21/1993	F	1 11595-110					
TULLY ESTELLE R				01/01/1969	XX	3425-771					

CLASS	CLASS%	DESCRIPTION			BN ID	BN	CARD	
1010	100	SINGLE FAMILY				1	1 of 1	
PMT NO	PMT DT	TY	DESC	AMOUNT	INSP	BY	1st	%
99-113	04/02/1999	7	OTHERS		09/02/2022	JD	100	100
		3	ALTERATIONS				100	100
		2	ADDITIONS				100	100

CD	T	AC/SF/UN	Ngh	Inf1	Inf2	ADJ BASE	SAF	Inf3	Lpi	VC	CREDIT AMT	ADJ VALUE	
100	S	6,777	HBR 1.00	100	1.00	100	1.00	616,000	5.17	100	1.00	R08 1.40	495,890

TOTAL	6,777 SF	ZONING		FRNT	261	ASSESSED	CURRENT	PREVIOUS
Ngh	HARBOR	NOTE	LAND	495,900	418,600			
Inf1	FACTOR 100		BUILDING	281,600	250,100			
Inf2	PHY 100		DETACHED	0	0			
			OTHER	0	0			
			<b>TOTAL</b>	<b>777,500</b>	<b>668,700</b>			

TY	QUAL	COND	DIM/NOTE	YB	UNITS	ADJ PRICE	RCNLD

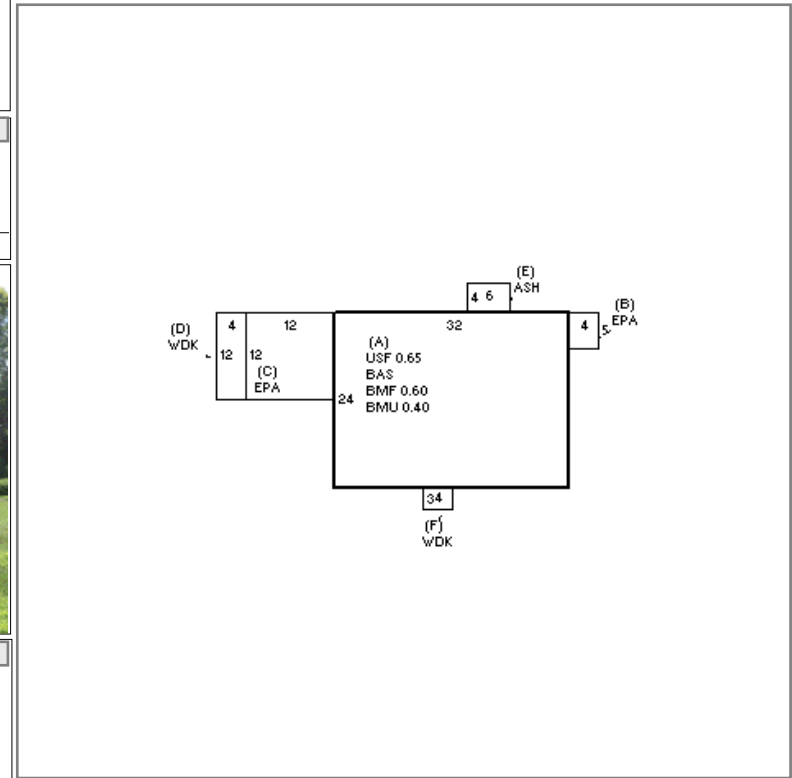

BUILDING	CD	ADJ	DESC	MEASURE	7/31/2023	JD
MODEL	1		RESIDENTIAL	LIST	7/31/2023	EST
STYLE	4	1.10	CAPE [100%]	REVIEW	9/2/2022	JD
QUALITY	A	1.00	AVERAGE [100%]			
FRAME	1	1.00	WOOD FRAME [100%]			

BLDG COMMENTS  
MLS

YEAR BLT	1955	SIZE ADJ	1.000	ELEMENT	CD	DESCRIPTION	ADJ	S	BAT	T	DESCRIPTION	UNITS	YB	ADJ PRICE	RCN	TOTAL RCN	380,580	
NET AREA	1,267	DETAIL ADJ	1.100	FOUNDATION	4	CONT BSMT WALL	1.00	A	BMU	N	BSMT UNFINISHED	307		51.23	15,729	CONDITION ELEM	CD	
\$NLA(RCN)	\$300	OVERALL	1.000	EXT COVER	1	WD SHINGLES	1.00	A	BMF	N	BSMT FINISH-SEP	461		71.92	33,157	EXTERIOR	A	
CAPACITY			UNITS	ADJ	ROOF SHAPE	1	GABLE	1.00	A	BAS	L	BASE AREA	768	1955	245.33	188,413	INTERIOR	G
STORIES	1.65	1.00	ROOF COVER	1	ASPH SHINGLES	1.00	A	USF	L	UPPER STORY FIN	499	1955	223.10	111,327	KITCHEN	G		
ROOMS	6	1.00	FLOOR COVER	14	COMB	1.00	+	EPA	N	ENCLOSED PORCH	164		90.20	14,793	BATHS	G		
BEDROOMS	3	1.00	INT FINISH	1	PLASTER	1.00	+	WDK	N	WOOD DECK	60		38.40	2,304	HEAT	U		
BATHROOMS	2	1.00	HEATING/COOLING	1	FORCED AIR	1.00	E	ASH	N	ATT SHED	24		22.33	536	ELECT	A		
# 1/2 BATHS	1	1.00	FUEL SOURCE	2	GAS	1.00		F11	O	FPL 1S 1OP	1		7,281.00	7,281				
TOT FIXTURES	8	\$7,040																
# UNITS	1	1.00																

EFF.YR/AGE	1984 / 38
COND	26 26 %
FUNC	0
ECON	0
DEPR	26 % GD 74
RCNLD	\$281,600