

Key: 5339

Town of SCITUATE - Fiscal Year 2024

10/18/2023 5:31 pm SEQ #: 5.083

LEGALS

CURRENT OWNER				PARCEL ID				LOCATION			
PASSERI RICHARD J TR & PASSERI ESTELLE E TR 160 ELM STREET BYFIELD, MA 01922-2818				45-7-3-0				9 RICHFIELD RD			
TRANSFER HISTORY				DOS	T	SALE PRICE	BK-PG (Cert)				
PASSERI RICHARD J TR & PASSERI ESTELLE & RICHARD				03/20/2019	F		1 (128243)				
HARMS FREDERICK G & ESTEL				06/07/1979	QS		(61987)				
				01/01/1953	XX		88-187				

CLASS	CLASS%	DESCRIPTION			BN ID	BN	CARD	
1010	100	SINGLE FAMILY				1	1 of 1	
PMT NO	PMT DT	TY	DESC	AMOUNT	INSP	BY	1st	%
12-754	12/06/2012	2	ADDITIONS	150,000	08/06/2013	SJ	100	100
98-483	09/22/1998	3	ALTERATIONS				100	100

LAND

CD	T	AC/SF/UN	Ngh	Infl1	Infl2	ADJ BASE	SAF	Infl3	Lpi	VC	CREDIT AMT	ADJ VALUE	
100	S	7,500 OS	1.00	100	1.00	100	1.00	440,000	4.70	100	1.00	R03 1.00	355,920

TOTAL	7,500 SF	ZONING	FRNT	80	ASSESSED	CURRENT	PREVIOUS
Ngh	OCEANSIDE	NOTE	LAND	355,900	323,600		
Infl1	FACTOR 100		BUILDING	254,700	226,700		
Infl2	PHY 100		DETACHED	0	0		
			OTHER	0	0		
TOTAL				610,600	550,300		

DETACHED

TY	QUAL	COND	DIM/NOTE	YB	UNITS	ADJ PRICE	RCNLD

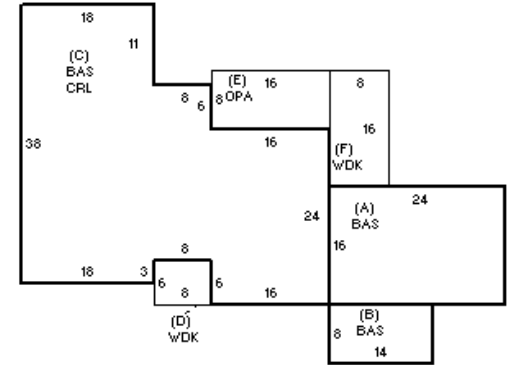

BUILDING

BUILDING	CD	ADJ	DESC	MEASURE	8/6/2013	SJ
MODEL	1		RESIDENTIAL	LIST	8/6/2013	SJ
STYLE	1	0.85	RANCH [100%]	REVIEW	3/25/2011	ER
QUALITY	A	1.00	AVERAGE [100%]			
FRAME	1	1.00	WOOD FRAME [100%]			

BLDG COMMENTS

BUILDING

YEAR BLT	1947	SIZE ADJ	1.000	ELEMENT	CD	DESCRIPTION	ADJ	S	BAT	T	DESCRIPTION	UNITS	YB	ADJ PRICE	RCN	TOTAL RCN	322,457												
NET AREA	1,756	DETAIL ADJ	0.807	FOUNDATION	2	SLAB	0.95	+	BAS	L	BASE AREA	496	1947	166.71	82,690														
\$NLA(RCN)	\$184	OVERALL	1.000	EXT COVER	2	CLAPBOARD	1.00	C	CRL	N	BSMT CRAWL	1,260		9.91	12,484														
				ROOF SHAPE	1	GABLE	1.00	C	BAS	L	BASE AREA	1,260	2013	166.71	210,059														
				ROOF COVER	1	ASPH SHINGLES	1.00	+	WDK	N	WOOD DECK	176		38.40	6,758														
				FLOOR COVER	2	SOFTWOOD	1.00	E	OPA	N	OPEN PORCH	128		51.50	6,592														
				INT FINISH	2	DRYWALL	1.00																						
				HEATING/COOLING	1	FORCED AIR	1.00																						
				FUEL SOURCE	2	GAS	1.00																						
				<table border="1"> <tr> <td>EXTERIOR</td> <td></td> </tr> <tr> <td>INTERIOR</td> <td></td> </tr> <tr> <td>KITCHEN</td> <td></td> </tr> <tr> <td>BATHS</td> <td></td> </tr> <tr> <td>HEAT</td> <td></td> </tr> <tr> <td>ELECT</td> <td></td> </tr> </table>														EXTERIOR		INTERIOR		KITCHEN		BATHS		HEAT		ELECT	
EXTERIOR																													
INTERIOR																													
KITCHEN																													
BATHS																													
HEAT																													
ELECT																													
				<table border="1"> <tr> <td>EFF.YR/AGE</td> <td>2000 / 22</td> </tr> <tr> <td>COND</td> <td>20 20 %</td> </tr> <tr> <td>FUNC</td> <td>0</td> </tr> <tr> <td>ECON</td> <td>0</td> </tr> <tr> <td>DEPR</td> <td>21 % GD 79</td> </tr> </table>														EFF.YR/AGE	2000 / 22	COND	20 20 %	FUNC	0	ECON	0	DEPR	21 % GD 79		
EFF.YR/AGE	2000 / 22																												
COND	20 20 %																												
FUNC	0																												
ECON	0																												
DEPR	21 % GD 79																												
				<table border="1"> <tr> <td>RCNLD</td> <td>\$254,700</td> </tr> </table>														RCNLD	\$254,700										
RCNLD	\$254,700																												