

Key: 5443

Town of SCITUATE - Fiscal Year 2024

10/18/2023 5:31 pm SEQ #: 5.174

LEG
AL
LAND

CURRENT OWNER				PARCEL ID				LOCATION				
CIGNA CHARLES & MARANDA 38 TILDEN RD SCITUATE, MA 02066				45-16-31-0				38 TILDEN RD				
TRANSFER HISTORY				DOS	T	SALE PRICE	BK-PG (Cert)					
CIGNA CHARLES & MARANDA				06/25/2018	QS	832,000	49959-157					
BRAUN PHILIP & JESSICA P				02/26/2016	QS	755,000	46627-65					
MARROCCO PARTNERS, LLC				06/13/2014	O	275,000	44416-318					
CD	T	AC/SF/UN	Ngh	Inf1	Inf2	ADJ BASE	SAF	Inf3	Lpi	VC	CREDIT AMT	ADJ VALUE
100	S	19,750	HBR 1.00	100	1.00	616,000	1.89	100	1.00	R02	1.40	528,310

CLASS	CLASS%	DESCRIPTION			BN ID	BN	CARD	
1010	100	SINGLE FAMILY				1	1 of 1	
PMT NO	PMT DT	TY	DESC	AMOUNT	INSP	BY	1st	%
21-224	03/15/2021	2	ADDITIONS	60,000	05/12/2021	JD	100	0
21-224	03/15/2021	2	ADDITIONS	60,000	07/18/2022	JD	100	100
14-309	06/03/2014	3	ALTERATIONS	300,000	08/06/2015	SJ	100	100

TOTAL	19,750 SF	ZONING	FRNT	109	ASSESSED	CURRENT	PREVIOUS
Ngh	HARBOR	NOTE			LAND	528,300	446,000
Inf1	FACTOR 100		BUILDING	882,900	785,200		
Inf2	PHY 100		DETACHED	26,800	25,500		
			OTHER	0	0		
					TOTAL	1,438,000	1,256,700

TY	QUAL	COND	DIM/NOTE	YB	UNITS	ADJ PRICE	RCNLD
HTB	A	1.00	20 0.80		1	5,181.80	4,100
PTD	A	1.00	10 0.90		300	7.90	2,100
IPG	G	1.20	10 0.90	2022	512	44.73	20,600

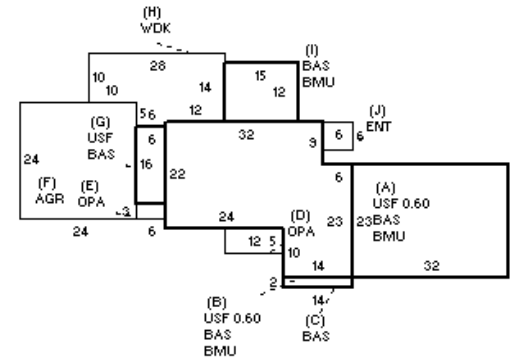

BUILDING	CD	ADJ	DESC	MEASURE	5/12/2021	JD
MODEL	1		RESIDENTIAL	LIST	5/12/2021	EST
STYLE	19	1.15	ANTIQUE [100%]	REVIEW	7/18/2022	JD
QUALITY	+	1.10	AVG +/GOOD - [100%]			
FRAME	1	1.00	WOOD FRAME [100%]			

BLDG COMMENTS

YEAR BLT	1849	SIZE ADJ	1.000
NET AREA	3,053	DETAIL ADJ	1.196
\$NLA(RCN)	\$289	OVERALL	1.000
CAPACITY		UNITS	ADJ
STORIES		1.5	1.00
ROOMS		8	1.00
BEDROOMS		4	1.00
BATHROOMS		2	1.00
# 1/2 BATHS		1	1.00
TOT FIXTURES		8	\$8,419
# UNITS		1	1.00

ELEMENT	CD	DESCRIPTION	ADJ	S	BAT	T	DESCRIPTION	UNITS	YB	ADJ PRICE	RCN
FOUNDATION	4	CONT BSMT WALL	1.00	+	BMU	N	BSMT UNFINISHED	1,838		45.11	82,905
EXT COVER	4	VINYL	1.00	+	USF	L	UPPER STORY FIN	538	1849	225.72	121,437
ROOF SHAPE	1	GABLE	1.00	+	BAS	L	BASE AREA	1,102	2014	248.21	273,526
ROOF COVER	1	ASPH SHINGLES	1.00	B	USF	L	UPPER STORY FIN	553	2014	225.72	124,823
FLOOR COVER	2	SOFTWOOD	1.00	+	BAS	L	BASE AREA	860	1849	248.21	213,459
INT FINISH	1	PLASTER	1.00	+	OPA	N	OPEN PORCH	78		56.65	4,419
HEATING/COOLING	11	HW/COOL AIR	1.04	F	AGR	N	ATT GARAGE	576		46.91	27,019
FUEL SOURCE	2	GAS	1.00	H	WDK	N	WOOD DECK	358		42.24	15,122
				J	ENT	N	ENCLOSED ENTRY	36		107.46	3,869
					GFP	O	GAS FIREPLACE	1		6,111.60	6,112
					ODS	O	OUT DOOR SHOWER	1		1,765.50	1,766

TOTAL RCN	882,874
CONDITION ELEM	CD
EXTERIOR	V
INTERIOR	V
KITCHEN	V
BATHS	V
HEAT	U
ELECT	U
EFF.YR/AGE	2022 / 0
COND	0 0 %
FUNC	0
ECON	0
DEPR	0 % GD 100
RCNLD	\$882,900