

Key: 5706

Town of SCITUATE - Fiscal Year 2024

10/18/2023 5:31 pm SEQ #: 5.432

LEGAL

CURRENT OWNER				PARCEL ID				LOCATION			
MACEACHERN KEVIN M & RUTH M 18 LONGMEADOW RD SCITUATE, MA 02066				27-6-50-0				18 LONGMEADOW RD			
TRANSFER HISTORY				DOS	T	SALE PRICE	BK-PG (Cert)				
MACEACHERN KEVIN M & RUTH				04/16/2008	QS	555,000	35857-152				
MAY F JANE				11/29/1990	QS		10051-237				
MAY WALTER J AND F JANE				01/01/1976	XX		4108-437				

CLASS	CLASS%	DESCRIPTION			BN ID	BN	CARD	
1010	100	SINGLE FAMILY				1	1 of 1	
PMT NO	PMT DT	TY	DESC	AMOUNT	INSP	BY	1st	%
22-0471	05/04/2022	3	ALTERATIONS	12,000	06/23/2022	JD	100	100
90-431	07/24/1990	3	ALTERATIONS				100	100

LAND

CD	T	AC/SF/UN	Ngh	Infl1	Infl2	ADJ BASE	SAF	Infl3	Lpi	VC	CREDIT AMT	ADJ VALUE
100	S	40,000	NS 1.00	100	1.00	440,000	1.00	100	1.00	R04	1.00	404,040
300	A	0.312	NS 1.00	100	1.00	19,800	1.00	100	1.00	R04	1.00	6,180

TOTAL	1.230 Acres	ZONING	FRNT	132	ASSESSED	CURRENT	PREVIOUS
Ngh	NO. SCITUATE	NOTE IN M21	LAND	410,200	373,200		
Infl1	FACTOR 100		BUILDING	497,100	459,700		
Infl2	PHY 100		DETACHED	0	0		
			OTHER	0	0		
			TOTAL	907,300	832,900		

DETACHED

TY	QUAL	COND	DIM/NOTE	YB	UNITS	ADJ PRICE	RCNLD

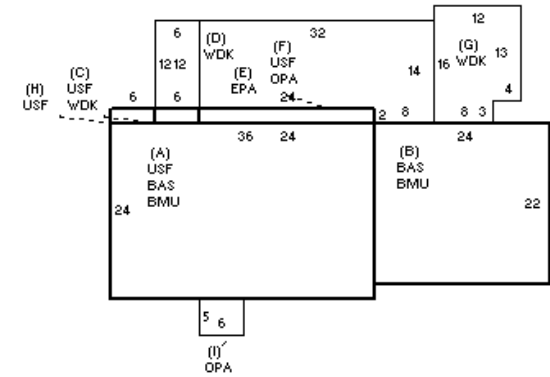

BUILDING

BUILDING	CD	ADJ	DESC	MEASURE	6/23/2022	JD
MODEL	1		RESIDENTIAL	LIST	6/23/2022	EST
STYLE	5	1.00	COLONIAL [100%]	REVIEW	3/22/2011	ER
QUALITY	+	1.10	AVG +/GOOD - [100%]			
FRAME	1	1.00	WOOD FRAME [100%]			

BLDG COMMENTS

G

YEAR BLT	1973	SIZE ADJ	1.000	ELEMENT	CD	DESCRIPTION	ADJ	S	BAT	T	DESCRIPTION	UNITS	YB	ADJ PRICE	RCN	TOTAL RCN	637,325		
NET AREA	2,328	DETAIL ADJ	1.020	FOUNDATION	4	CONT BSMT WALL	1.00	+	BMU	N	BSMT UNFINISHED	1,392		47.70	66,397	CONDITION ELEM	CD		
\$NLA(RCN)	\$274	OVERALL	1.000	EXT COVER	1	WD SHINGLES	1.00	+	BAS	L	BASE AREA	1,392	1973	220.20	306,515	EXTERIOR	G		
				ROOF SHAPE	2	HIP	1.00	+	WDK	N	WOOD DECK	264		42.24	11,152	INTERIOR	G		
				ROOF COVER	1	ASPH SHINGLES	1.00	E	EPA	N	ENCLOSED PORCH	400		99.22	39,688	KITCHEN	G		
				FLOOR COVER	14	COMB	1.00	+	OPA	N	OPEN PORCH	78		56.65	4,419	BATHS	G		
				INT FINISH	2	DRYWALL	1.00	+	USF	L	UPPER STORY FIN	936	1973	200.25	187,430	HEAT	A		
				HEATING/COOLING	2	HOT WATER	1.02		BMG	O	BSMT GARAGE	2		2,740.10	5,480	ELECT	A		
				FUEL SOURCE	2	GAS	1.00		F21	O	FPL 2S 1OP	1		9,062.90	9,063				
CAPACITY		UNITS	ADJ															EFF.YR/AGE	1997 / 25
STORIES	2	1.00																COND	22 22 %
ROOMS	8	1.00																FUNC	0
BEDROOMS	4	1.00																ECON	0
BATHROOMS	2	1.00																DEPR	22 % GD 78
# 1/2 BATHS	1	1.00																RCNLD	\$497,100
TOT FIXTURES	8	\$7,181																	
# UNITS	1	1.00																	