

Key: 5729

Town of SCITUATE - Fiscal Year 2024

10/18/2023 5:31 pm SEQ #: 5.455

LEGAL

CURRENT OWNER				PARCEL ID				LOCATION			
SULLIVAN MARY E, TR 96 WARREN ST WALTHAM, MA 02453				46-1-34-0				25 REBECCA RD			
TRANSFER HISTORY				DOS	T	SALE PRICE	BK-PG (Cert)				
SULLIVAN MARY E, TR				07/14/2011	F		1 40121-297				
SULLIVAN MARY E				01/01/1971	QS		3602-305				
MCCORMACK SYLVESTER V & M				01/01/1945	XX		1863-240				

CLASS	CLASS%	DESCRIPTION			BN ID	BN	CARD	
1010	100	SINGLE FAMILY				1	1 of 1	
PMT NO	PMT DT	TY	DESC	AMOUNT	INSP	BY	1st	%
20-197	03/23/2020	1	NEW CONST	325,000	07/15/2020	JD	100	5
20-197	03/23/2020	1	NEW CONST	325,000	04/21/2021	JD	100	100
06-236	05/01/2006	3	ALTERATIONS	3,000	08/03/2006	SJ	100	100
98-437	08/26/1998	3	ALTERATIONS				100	100
92-304	04/21/1992	3	ALTERATIONS				100	100

LAND

CD	T	AC/SF/UN	Ngh	Infl1	Infl2	ADJ BASE	SAF	Infl3	Lpi	VC	CREDIT AMT	ADJ VALUE	
100	S	5,160 OS	1.00	100	1.00	100	1.00	660,000	6.71	100	1.00	WF6 1.50	524,900

TOTAL	5,160 SF	ZONING		FRNT	33	ASSESSED	CURRENT	PREVIOUS
Ngh	OCEANSIDE	NOTE c/w 46-1-35 FY 2022	LAND	524,900	477,200			
Infl1	FACTOR 100		BUILDING	551,100	518,800			
Infl2	PHY 100		DETACHED	0	0			
			OTHER	0	0			
TOTAL			TOTAL	1,076,000	996,000			

DETACHED

TY	QUAL	COND	DIM/NOTE	YB	UNITS	ADJ PRICE	RCNLD

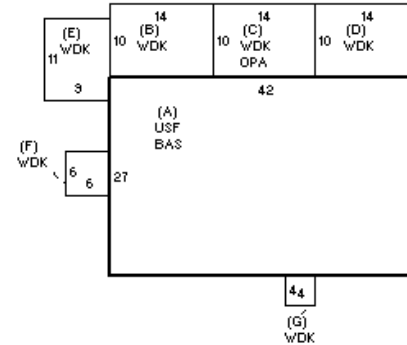

BUILDING

BUILDING	CD	ADJ	DESC	MEASURE	4/20/2021	JD
MODEL	1		RESIDENTIAL	LIST	4/20/2021	EST
STYLE	5	1.00	COLONIAL [100%]	REVIEW		
QUALITY	G	1.20	GOOD [100%]			
FRAME	1	1.00	WOOD FRAME [100%]			

BLDG COMMENTS

G

YEAR BLT	2020	SIZE ADJ	1.000	ELEMENT	CD	DESCRIPTION	ADJ	S	BAT	T	DESCRIPTION	UNITS	YB	ADJ PRICE	RCN	TOTAL RCN	562,348			
NET AREA	2,268	DETAIL ADJ	1.009	FOUNDATION	1	PIER	0.98	A	BAS	L	BASE AREA	1,134	2020	238.65	270,625	CONDITION ELEM	CD			
\$NLA(RCN)	\$248	OVERALL	1.000	EXT COVER	4	VINYL	1.00	A	USF	L	UPPER STORY FIN	1,134	2020	217.02	246,104	EXTERIOR	A			
				ROOF SHAPE	1	GABLE	1.00	+	WDK	N	WOOD DECK	571		46.08	26,311	INTERIOR	A			
				ROOF COVER	1	ASPH SHINGLES	1.00	C	OPA	N	OPEN PORCH	140		61.80	8,652	KITCHEN	A			
				FLOOR COVER	12	COMB	1.00									BATHS	A			
				INT FINISH	2	DRYWALL	1.00									HEAT	A			
				HEATING/COOLING	9	WARM/COOL AIR	1.03									ELECT	A			
				FUEL SOURCE	2	GAS	1.00													
																		EFF.YR/AGE	2020 / 2	
																		COND	2 2 %	
																		FUNC	0	
																		ECON	0	
																		DEPR	2 % GD 98	
																		RCNLD	\$551,100	