

Key: 5746

Town of SCITUATE - Fiscal Year 2024

10/18/2023 5:31 pm SEQ #: 5.471

LEG
AL
LAND

CURRENT OWNER				PARCEL ID				LOCATION				
BERGHOLTZ JEFFREY P & NANCY A 2 LIGHTHOUSE RD SCITUATE, MA 02066				46-5-42-0				2 LIGHTHOUSE RD				
TRANSFER HISTORY				DOS	T	SALE PRICE	BK-PG (Cert)					
BERGHOLTZ JEFFREY P & NAN				06/21/2022	QS	3,000,000	56937-249					
FINK SELENA A & LINDSAY &				05/22/2012	Q	1,120,000	41402-160					
MITMAN CLIFFORD JR & MILD				03/01/2000	QS	439,000	18318-338					
CD	T	AC/SF/UN	Ngh	Inf1	Inf2	ADJ BASE	SAF	Inf3	Lpi	VC	CREDIT AMT	ADJ VALUE
100	S	5,193	OS	1.00	100	1.00	100	1.00	WF1	1.90		665,060

CLASS	CLASS%	DESCRIPTION		BN ID	BN	CARD	
1010	100	SINGLE FAMILY			1	1 of 1	
PMT NO	PMT DT	TY	DESC	AMOUNT	INSP	BY	1st %
13-750	11/12/2013	7	OTHERS		03/16/2022	JD	100 100
13-750	11/12/2013	2	ADDITIONS	325,000	07/09/2014	MR	100 100
99-457	08/27/1999	3	ADDITIONS	325,000	08/03/2015	SJ	100 100
96-525	10/29/1996	3	ALTERATIONS				100 100

LAND

TOTAL	5,193 SF	ZONING	FRNT	38	ASSESSED	CURRENT	PREVIOUS
Ngh	OCEANSIDE	NOTE			LAND	665,100	755,700
Inf1	FACTOR 100		BUILDING	2,180,200	1,467,400		
Inf2	PHY 100		DETACHED	5,600	5,300		
			OTHER	0	0		
			TOTAL	2,850,900	2,228,400		

DETACHED

TY	QUAL	COND	DIM/NOTE	YB	UNITS	ADJ PRICE	RCNLD
HTB	G	1.20	10 0.90		1	6,218.16	5,600



BLDG COMMENTS
MLS

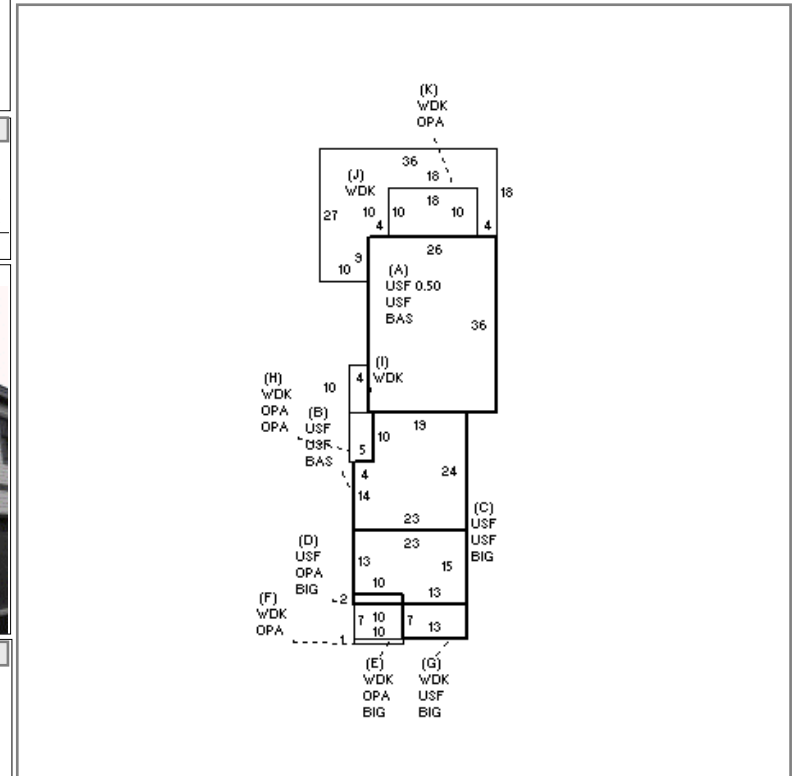

BUILDING

BUILDING	CD	ADJ	DESC	MEASURE	7/9/2014	MR
MODEL	1		RESIDENTIAL	LIST	8/3/2014	EST
STYLE	20	1.35	NEW STYLE [100%]	REVIEW	3/16/2022	JD
QUALITY	E	1.80	EXCELLENT [100%]			
FRAME	1	1.00	WOOD FRAME [100%]			

INDING

YEAR BLT	1980	SIZE ADJ	1.000	ELEMENT	CD	DESCRIPTION	ADJ	S	BAT	T	DESCRIPTION	UNITS	YB	ADJ PRICE	RCN	TOTAL RCN	2,224,672		
NET AREA	4,637	DETAIL ADJ	1.404	FOUNDATION	4	CONT BSMT WALL	1.00	+	BAS	L	BASE AREA	1,448	1980	456.02	660,317	CONDITION ELEM	CD		
\$NLA(RCN)	\$480	OVERALL	1.000	EXT COVER	1	WD SHINGLES	1.00	+	USF	L	UPPER STORY FIN	3,189		414.70	1,322,483	EXTERIOR	V		
				ROOF SHAPE	1	GABLE	1.00	+	BIG	N	BUILT-IN GARAGE	506		111.12	56,225	INTERIOR	V		
				ROOF COVER	1	ASPH SHINGLES	1.00	+	OPA	N	OPEN PORCH	380		92.70	35,226	KITCHEN	V		
				FLOOR COVER	13	COMB	1.00	+	WDK	N	WOOD DECK	999		69.12	69,052	BATHS	V		
				INT FINISH	2	DRYWALL	1.00		F21	O	FPL 2S 1OP	1		14,830.20	14,830	HEAT	U		
				HEATING/COOLING	11	HW/COOL AIR	1.04		FPL	O	FIREPLACE	2		14,062.50	28,125	ELECT	U		
				FUEL SOURCE	2	GAS	1.00												
																		EFF.YR/AGE	2020 / 2
																		COND	2 2 %
																		FUNC	0
																		ECON	0
																		DEPR	2 % GD 98
																		RCNLD	\$2,180,200