

Key: 5767

Town of SCITUATE - Fiscal Year 2024

10/18/2023 5:31 pm SEQ #: 5.493

LEGAL

LAND

DETACHED

BUILDING

CURRENT OWNER				PARCEL ID				LOCATION			
RYAN ROBERT TR, MARYANNA TR & RATTO BARBARA M TR 23 VINAL AV SCITUATE, MA 02066				50-9-5-0				23 VINAL AV			
TRANSFER HISTORY				DOS	T	SALE PRICE		BK-PG (Cert)			
RYAN ROBERT TR, MARYANNA				02/08/2022	F	1 56418-204					
RATTO BARBARA M &				10/24/2012	A	160,000 42140-349					
RATTO FRANK P & ELEANOR				01/01/1965	QS	3142-1					

CLASS	CLASS%	DESCRIPTION			BN ID	BN	CARD	
1010	100	SINGLE FAMILY				1	1 of 1	
PMT NO	PMT DT	TY	DESC	AMOUNT	INSP	BY	1st	%
E22-0111	02/16/2022	3	ALTERATIONS	50,000	04/25/2022	JD	100	50
E22-0111	02/16/2022	3	ALTERATIONS	50,000	05/19/2023	NC	100	100
21-1352	10/19/2021	2	ADDITIONS	407,000	04/25/2022	JD	100	75
21-1352	10/19/2021	2	ADDITIONS	407,000	05/19/2023	NC	100	100

CD	T	AC/SF/UN	Ngh	Inf1	Inf2	ADJ BASE	SAF	Inf3	Lpi	VC	CREDIT AMT	ADJ VALUE
100	S	19,566	HBR 1.00	100	1.00	100	1.00	660,000	1.91	100	1.00	565,640

TOTAL	19,566 SF	ZONING		FRNT	118	ASSESSED	CURRENT	PREVIOUS
Ngh	HARBOR	NOTE		LAND	565,600	479,900		
Inf1	FACTOR 100		BUILDING	732,000	581,600			
Inf2	PHY 100		DETACHED	1,400	1,300			
			OTHER	0	0			
				TOTAL	1,299,000	1,062,800		

TY	QUAL	COND	DIM/NOTE	YB	UNITS	ADJ PRICE	RCNLD
SHF	G	1.20	10 0.90 8X10	2021	80	19.16	1,400

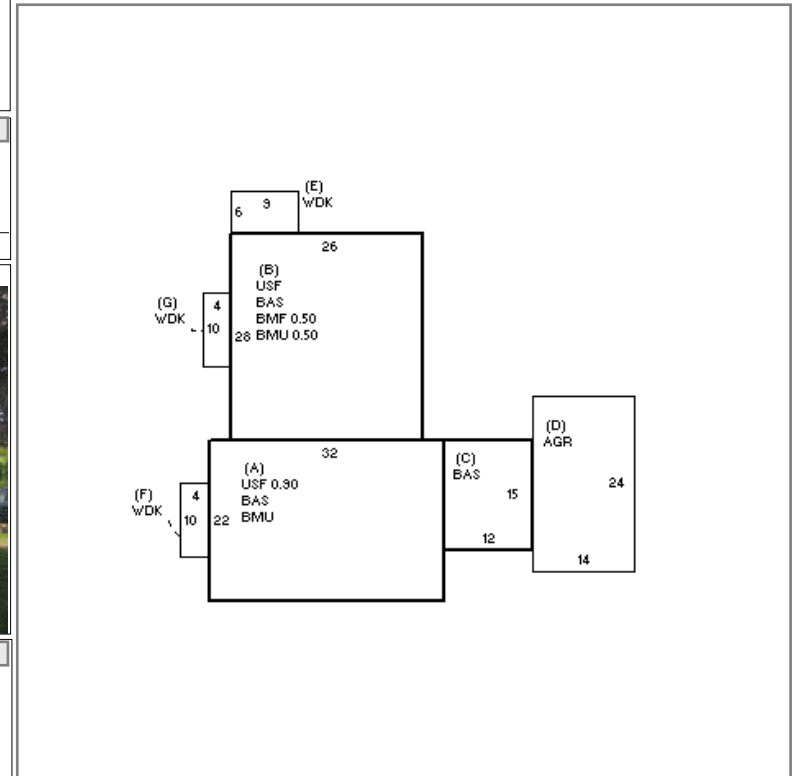

BUILDING	CD	ADJ	DESC	MEASURE	4/25/2022	JD
MODEL	1		RESIDENTIAL	LIST	4/25/2022	EST
STYLE	4	1.10	CAPE [100%]	REVIEW	7/5/2023	MR
QUALITY	A	1.00	AVERAGE [100%]			
FRAME	1	1.00	WOOD FRAME [100%]			

BLDG COMMENTS
IN-LAW APT/ LEGAL ACCESSORY DWELLING

YEAR BLT	1955	SIZE ADJ	1.000	ELEMENT	CD	DESCRIPTION	ADJ	S	BAT	T	DESCRIPTION	UNITS	YB	ADJ PRICE	RCN	TOTAL RCN	731,981		
NET AREA	2,974	DETAIL ADJ	1.166	FOUNDATION	4	CONT BSMT WALL	1.00	+	BMU	N	BSMT UNFINISHED	1,068		43.07	45,997	CONDITION ELEM	CD		
\$NLA(RCN)	\$246	OVERALL	1.000	EXT COVER	4	VINYL	1.00	A	USF	L	UPPER STORY FIN	634	2022	200.72	127,258	EXTERIOR	G		
				ROOF SHAPE	1	GABLE	1.00	B	BMF	N	BSMT FINISH-SEP	364		60.46	22,007	INTERIOR	V		
				ROOF COVER	1	ASPH SHINGLES	1.00	B	USF	L	UPPER STORY FIN	728	2021	200.72	146,126	KITCHEN	V		
				FLOOR COVER	14	COMB	1.00	+	BAS	L	BASE AREA	1,612	1955	220.72	355,804	BATHS	V		
				INT FINISH	1	PLASTER	1.00	D	AGR	N	ATT GARAGE	336		49.48	16,625	HEAT	U		
				HEATING/COOLING	11	HW/COOL AIR	1.04	+	WDK	N	WOOD DECK	134		38.40	5,146	ELECT	U		
				FUEL SOURCE	1	OIL	1.00	GFP	O		GAS FIREPLACE	1		5,556.00	5,556				
																		EFF.YR/AGE	2022 / 0
																		COND	0 0 %
																		FUNC	0
																		ECON	0
																		DEPR	0 % GD 100
																		RCNLD	\$732,000