

Key: 5782

Town of SCITUATE - Fiscal Year 2024

10/18/2023 5:31 pm SEQ #: 5.508

LEGALS

CURRENT OWNER				PARCEL ID				LOCATION				
PRITCHARD KAREN L TR 36 MEETING HOUSE LN SCITUATE, MA 02066				55-4-4-0				36 MEETING HOUSE LN				
TRANSFER HISTORY				DOS	T	SALE PRICE	BK-PG (Cert)					
PRITCHARD KAREN L TR				08/25/2022	F	1	57168-163					
PRITCHARD KAREN L & STEPH				07/21/2014	O	585,000	44548-305					
SWIDER CHRISTOPHER E & ED				03/31/2010	F	-100	38376-53					

CLASS	CLASS%	DESCRIPTION			BN ID	BN	CARD	
1010	100	SINGLE FAMILY				1	1 of 1	
PMT NO	PMT DT	TY	DESC	AMOUNT	INSP	BY	1st	%
15-892	12/31/2015	7	OTHERS	37,298	05/19/2016	SJ	100	30
15-892	12/31/2015	7	OTHERS	37,298	08/10/2017	SJ	100	100
14-93	11/18/2014	1	NEW CONST	600,000	06/09/2015	SJ	100	50
14-93	11/18/2014	1	NEW CONST	600,000	05/19/2016	SJ	100	100
90-136	04/09/1990	3	ALTERATIONS				100	100

LAND

CD	T	AC/SF/UN	Ngh	Inf1	Inf2	ADJ BASE	SAF	Inf3	Lpi	VC	CREDIT AMT	ADJ VALUE
100	S	40,000	HBR 1.00	100	1.00	660,000	1.00	100	1.00	WV3		606,060
300	A	0.242	HBR 1.00	100	1.00	29,700	1.00	100	1.00	WV3		7,190

TOTAL	1.160 Acres	ZONING	FRNT	126	ASSESSED	CURRENT	PREVIOUS
Ngh	HARBOR	NOTE			LAND	613,300	520,700
Inf1	FACTOR 100		BUILDING	1,129,700	980,200		
Inf2	PHY 100		DETACHED	25,600	24,400		
			OTHER	0	0		
			<b>TOTAL</b>		<b>1,768,600</b>	<b>1,525,300</b>	

DETACHED

TY	QUAL	COND	DIM/NOTE	YB	UNITS	ADJ PRICE	RCNLD	
SHF	G	1.20	10 0.90	14 X 16	2012	224	14.42	2,900
IPF	G	1.20	10 0.90	16 X 40	2016	640	39.35	22,700



BLDG COMMENTS

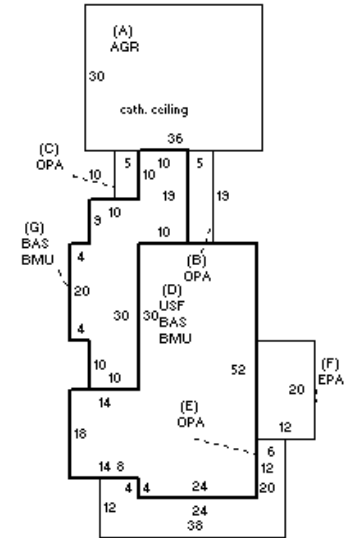

BUILDING

BUILDING	CD	ADJ	DESC	MEASURE	6/9/2015	SJ
MODEL	1		RESIDENTIAL	LIST	5/19/2016	EST
STYLE	5	1.00	COLONIAL [100%]	REVIEW		
QUALITY	V	1.40	VERY GOOD [100%]			
FRAME	1	1.00	WOOD FRAME [100%]			

G

YEAR BLT	2015	SIZE ADJ	1.000	ELEMENT	CD	DESCRIPTION	ADJ	S	BAT	T	DESCRIPTION	UNITS	YB	ADJ PRICE	RCN	TOTAL RCN	1,214,696		
NET AREA	3,660	DETAIL ADJ	1.030	FOUNDATION	4	CONT BSMT WALL	1.00	A	AGR	N	ATT GARAGE	1,080		53.47	57,744				
\$NLA(RCN)	\$332	OVERALL	1.000	EXT COVER	2	CLAPBOARD	1.00	+	OPA	N	OPEN PORCH	553		72.10	39,872				
				ROOF SHAPE	1	GABLE	1.00	+	BMU	N	BSMT UNFINISHED	2,160		55.87	120,690				
				ROOF COVER	1	ASPH SHINGLES	1.00	+	BAS	L	BASE AREA	2,160	2015	266.28	575,166				
				FLOOR COVER	12	COMB	1.00	D	USF	L	UPPER STORY FIN	1,500	2015	242.15	363,231				
				INT FINISH	1	PLASTER	1.00	F	EPA	N	ENCLOSED PORCH	240		126.28	30,307				
				HEATING/COOLING	9	WARM/COOL AIR	1.03	F21	O		FPL 2S 1OP	1		11,534.60	11,535				
				FUEL SOURCE	2	GAS	1.00												
CAPACITY		UNITS	ADJ															TOTAL RCN	1,214,696
STORIES		2	1.00															CONDITION ELEM	CD
ROOMS		8	1.00															EXTERIOR	
BEDROOMS		4	1.00															INTERIOR	
BATHROOMS		4	1.00															KITCHEN	
# 1/2 BATHS		1	1.00															BATHS	
TOT FIXTURES		14	\$16,150															HEAT	
# UNITS		1	1.00															ELECT	
EFF.YR/AGE		2015 / 7																COND	7 7 %
FUNC		0																FUNC	0
ECON		0																ECON	0
DEPR		7 % GD																DEPR	93
RCNLD																		RCNLD	\$1,129,700