

Key: 5812

Town of SCITUATE - Fiscal Year 2024

10/18/2023 5:31 pm SEQ #: 5.537

LEGAL

CURRENT OWNER				PARCEL ID				LOCATION			
KENNEWAY BETHANY J 8 VINAL AV SCITUATE, MA 02066				50-10-26-0				8 VINAL AV			
TRANSFER HISTORY				DOS	T	SALE PRICE	BK-PG (Cert)				
KENNEWAY BETHANY J				12/10/2014	H	405,000	45034-9				
LOVE DENNIS N & JENNIFER				08/14/2006	H	425,000	33185-254				
MALLOY FRANCIS JR & MARY				01/01/1961	QS	2792-143					

CLASS	CLASS%	DESCRIPTION			BN ID	BN	CARD	
1010	100	SINGLE FAMILY				1	1 of 1	
PMT NO	PMT DT	TY	DESC	AMOUNT	INSP	BY	1st	%
06-549	09/11/2006	2	ADDITIONS	60,000	07/31/2007	SJ	100	100
90-612	10/05/1990	3	ALTERATIONS				100	100
90-303	06/07/1990	3	ALTERATIONS				100	100

LAND

CD	T	AC/SF/UN	Ngh	Infl1	Infl2	ADJ BASE	SAF	Infl3	Lpi	VC	CREDIT AMT	ADJ VALUE	
100	S	18,399	HBR	1.00	100	1.00	100	1.00	660,000	2.02	100	1.00	563,040

DETACHED

TOTAL	18,399 SF	ZONING	FRNT	122	ASSESSED	CURRENT	PREVIOUS
Ngh	HARBOR	NOTE	LAND	563,000	477,700		
Infl1	FACTOR 100		BUILDING	447,600	403,700		
Infl2	PHY 100		DETACHED	0	0		
			OTHER	0	0		
			TOTAL	1,010,600	881,400		

PHOTO 09/26/2003

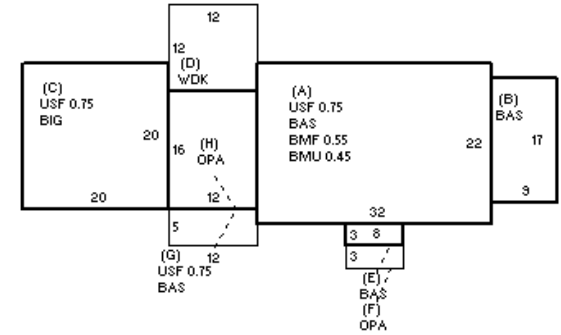
BUILDING

BUILDING	CD	ADJ	DESC	MEASURE	10/6/2014	SJ
MODEL	1		RESIDENTIAL	LIST	10/6/2014	EST
STYLE	4	1.10	CAPE [100%]	REVIEW	3/22/2011	ER
QUALITY	+	1.10	AVG +/GOOD - [100%]	FY12 QUALITY CHANGE FROM GD TO AVG PER FIELD REVIEW.		
FRAME	1	1.00	WOOD FRAME [100%]			

G

YEAR BLT	1951	SIZE ADJ	1.000	ELEMENT	CD	DESCRIPTION	ADJ	S	BAT	T	DESCRIPTION	UNITS	YB	ADJ PRICE	RCN	TOTAL RCN	596,759	
NET AREA	2,045	DETAIL ADJ	1.144	FOUNDATION	4	CONT BSMT WALL	1.00	A	BMU	N	BSMT UNFINISHED	317		58.12	18,424	CONDITION ELEM	CD	
\$NLA(RCN)	\$292	OVERALL	1.000	EXT COVER	1	WD SHINGLES	1.00	A	BMF	N	BSMT FINISH-SEP	387		81.59	31,574	EXTERIOR		
				ROOF SHAPE	1	GABLE	1.00	+	USF	L	UPPER STORY FIN	972	1951	229.66	223,225	INTERIOR		
				ROOF COVER	1	ASPH SHINGLES	1.00	+	BAS	L	BASE AREA	1,073	1951	252.54	270,973	KITCHEN		
				FLOOR COVER	14	COMB	1.00	C	BIG	N	BUILT-IN GARAGE	400		58.99	23,597	BATHS		
				INT FINISH	1	PLASTER	1.00	D	WDK	N	WOOD DECK	144		42.24	6,083	HEAT		
				HEATING/COOLING	11	HW/COOL AIR	1.04	+	OPA	N	OPEN PORCH	84		56.65	4,759	ELECT		
				FUEL SOURCE	1	OIL	1.00		F21	O	FPL 2S 1OP	1		9,062.90	9,063			
CAPACITY		UNITS	ADJ															
STORIES		1.75	1.00															
ROOMS		7	1.00															
BEDROOMS		3	1.00															
BATHROOMS		2	1.00															
# 1/2 BATHS		1	1.00															
TOT FIXTURES		9	\$9,061															
# UNITS		1	1.00															
EFF.YR/AGE 1990 / 32																		
COND 25 25 %																		
FUNC 0																		
ECON 0																		
DEPR 25 % GD 75																		
RCNLD \$447,600																		