

Key: 5814

Town of SCITUATE - Fiscal Year 2024

10/18/2023 5:31 pm SEQ #: 5.539

LEGAL

LAND

DETACHED

BUILDING

CURRENT OWNER				PARCEL ID				LOCATION			
GAUGHAN EDWARD J JR & KATHLEEN F PO BOX 740 SCITUATE, MA 02066				50-10-28-B				16 KENT ST			
TRANSFER HISTORY				DOS	T	SALE PRICE	BK-PG (Cert)				
GAUGHAN EDWARD J JR & WECKESSER FRANK				09/26/1983	QS	35,000	5464-130				
				10/22/1982	XX		5226-387				

CLASS	CLASS%	DESCRIPTION			BN ID	BN	CARD	
1010	100	SINGLE FAMILY				1	1 of 1	
PMT NO	PMT DT	TY	DESC	AMOUNT	INSP	BY	1st	%
22-0937	09/07/2022	3	ALTERATIONS	25,000	05/23/2023	NC	100	100
98-87	03/20/1998	2	ADDITIONS	12,500			100	100
91-322	07/10/1991	2	ADDITIONS	75,000			100	100

CD	T	AC/SF/UN	Ngh	Inf1	Inf2	ADJ BASE	SAF	Inf3	Lpi	VC	CREDIT AMT	ADJ VALUE
100	S	27,177	HBR 1.00	100	1.00	100	1.00	616,000	1.41	100	1.00	542,780

TOTAL	27,177 SF	ZONING	NOTED	FRNT	46	ASSESSED	CURRENT	PREVIOUS
Ngh	HARBOR	NOTED	LAND	542,800	458,200			
Inf1	FACTOR 100		BUILDING	620,300	552,900			
Inf2	PHY 100		DETACHED	12,000	11,400			
			OTHER	0	0			
			<b>TOTAL</b>	<b>1,175,100</b>	<b>1,022,500</b>			

TY	QUAL	COND	DIM/NOTE	YB	UNITS	ADJ PRICE	RCNLD
DGF	A	1.00	50 0.50	1985	528	45.29	12,000



BLDG COMMENTS

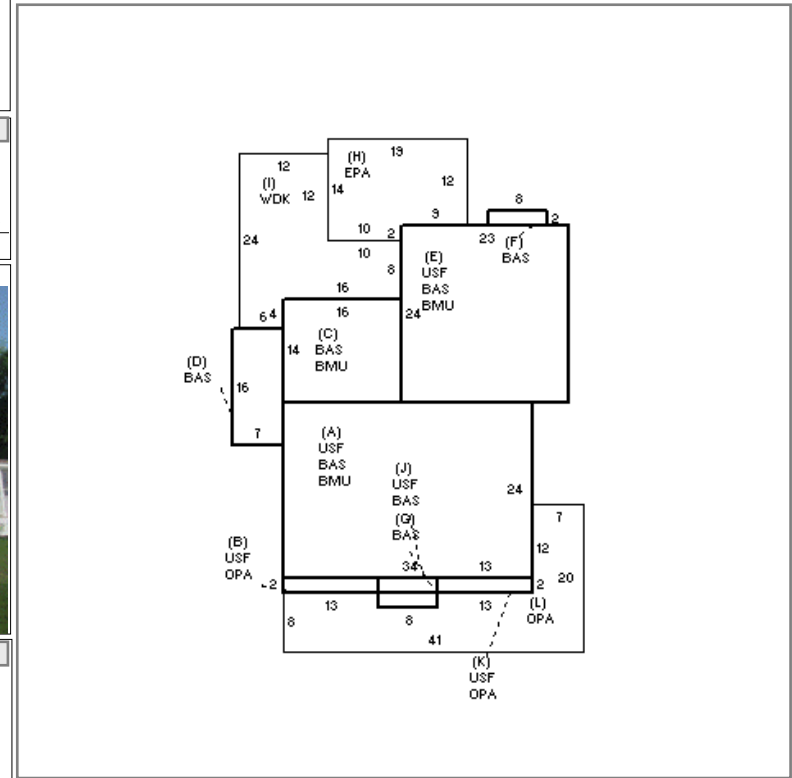

BUILDING	CD	ADJ	DESC	MEASURE	9/2/2009	PL
MODEL	1		RESIDENTIAL	LIST	9/2/2009	EST
STYLE	5	1.00	COLONIAL [100%]	REVIEW	6/29/2023	MR
QUALITY	+	1.10	AVG +/GOOD - [100%]			
FRAME	1	1.00	WOOD FRAME [100%]			

YEAR BLT	1983	SIZE ADJ	1.000	ELEMENT	CD	DESCRIPTION	ADJ	S	BAT	T	DESCRIPTION	UNITS	YB	ADJ PRICE	RCN
NET AREA	3,188	DETAIL ADJ	1.030	FOUNDATION	4	CONT BSMT WALL	1.00	+	BMU	N	BSMT UNFINISHED	1,592		46.36	73,799
\$NLA(RCN)	\$253	OVERALL	1.000	EXT COVER	2	CLAPBOARD	1.00	+	USF	L	UPPER STORY FIN	1,436	1983	193.30	277,585
				ROOF SHAPE	1	GABLE	1.00	+	OPA	N	OPEN PORCH	448		56.65	25,379
				ROOF COVER	2	WOOD SHINGLES	1.01	+	BAS	L	BASE AREA	1,752	1983	212.56	372,413
				FLOOR COVER	13	COMB	1.00	H	EPA	N	ENCLOSED PORCH	248		99.22	24,607
				INT FINISH	2	DRYWALL	1.00	I	WDK	N	WOOD DECK	344		42.24	14,531
				HEATING/COOLING	2	HOT WATER	1.02	F21	O	FPL 2S 1OP	1		9,062.90	9,063	
				FUEL SOURCE	99	N/A	1.00	GEN	O	GENERATOR	1		0.00		

TOTAL RCN	805,534
CONDITION ELEM	CD
EXTERIOR	G
INTERIOR	G
KITCHEN	A
BATHS	A
HEAT	A
ELECT	A
EFF.YR/AGE	1994 / 28
COND	24 24 %
FUNC	0
ECON	0
DEPR	23 % GD 77
RCNLD	\$620,300