

Key: 5930

Town of SCITUATE - Fiscal Year 2024

10/18/2023 5:31 pm SEQ #: 5.654

LEGAL

CURRENT OWNER				PARCEL ID				LOCATION			
ALBANO NICHOLAS S & SARA 62 ALLEN PLACE SCITUATE, MA 02066				50-3-12-0				62 ALLEN PL			
TRANSFER HISTORY				DOS	T	SALE PRICE		BK-PG (Cert)			
ALBANO NICHOLAS S & SARA				06/16/1982	QS	80,000		5162-153			
ABELL ROBERT F JR & DOROT				01/01/1965	XX			3086-368			
VINES GRACE W				01/01/1953	XX			2215-454			

CLASS	CLASS%	DESCRIPTION			BN ID	BN	CARD
1010	100	SINGLE FAMILY				1	1 of 1
PMT NO	PMT DT	TY	DESC	AMOUNT	INSP	BY	1st %

LAND

CD	T	AC/SF/UN	Ngh	Infl1	Infl2	ADJ BASE	SAF	Infl3	Lpi	VC	CREDIT AMT	ADJ VALUE
100	S	11,655	HBR 1.00	100	1.00	616,000	3.09	100	1.00	R08	1.40	510,050

TOTAL	11,674 SF	ZONING		FRNT	250	ASSESSED	CURRENT	PREVIOUS
Ngh	HARBOR	NOTE				LAND	510,100	430,600
Infl1	FACTOR 100					BUILDING	273,800	254,800
Infl2	PHY 100					DETACHED	7,500	7,100
						OTHER	0	0
						TOTAL	791,400	692,500

DETACHED

TY	QUAL	COND	DIM/NOTE	YB	UNITS	ADJ PRICE	RCNLD
DGF	A	1.00	70 0.30		560	44.59	7,500

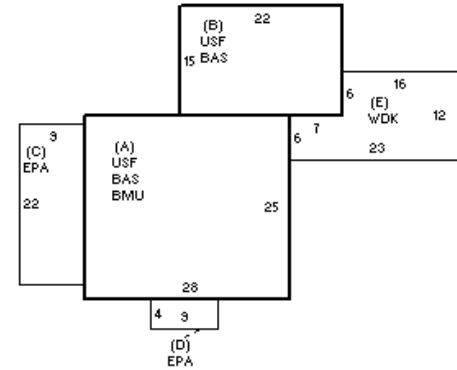

BUILDING

BUILDING	CD	ADJ	DESC	MEASURE	11/22/2010	PL
MODEL	1		RESIDENTIAL	LIST	11/22/2010	EST
STYLE	7	1.20	CONVENTIONAL [100%]	REVIEW	3/21/2011	ER
QUALITY	+	1.10	AVG +/GOOD - [100%]			
FRAME	1	1.00	WOOD FRAME [100%]			

BLDG COMMENTS
FY12 QUALITY CHANGE FROM GD TO AVG+ PER FIELD REVIEW. STYLE CHANGE FROM COL TO CONV.

G

YEAR BLT	1925	SIZE ADJ	1.000	ELEMENT	CD	DESCRIPTION	ADJ	S	BAT	T	DESCRIPTION	UNITS	YB	ADJ PRICE	RCN	TOTAL RCN	622,365	
NET AREA	2,060	DETAIL ADJ	1.224	FOUNDATION	4	CONT BSMT WALL	1.00	A	BMU	N	BSMT UNFINISHED	700		58.21	40,748	CONDITION ELEM	CD	
\$NLA(RCN)	\$302	OVERALL	1.000	EXT COVER	1	WD SHINGLES	1.00	+	USF	L	UPPER STORY FIN	1,030	1925	245.46	252,822	EXTERIOR		
				ROOF SHAPE	1	GABLE	1.00	+	BAS	L	BASE AREA	1,030	1925	269.91	278,012	INTERIOR		
				ROOF COVER	1	ASPH SHINGLES	1.00	+	EPA	N	ENCLOSED PORCH	234		99.22	23,218	KITCHEN		
				FLOOR COVER	2	SOFTWOOD	1.00	E	WDK	N	WOOD DECK	234		42.24	9,885	BATHS		
				INT FINISH	1	PLASTER	1.00		F21	O	FPL 2S 1OP	1		9,062.90	9,063	HEAT		
				HEATING/COOLING	2	HOT WATER	1.02									ELECT		
				FUEL SOURCE	99	N/A	1.00											
																	EFF.YR/AGE	1956 / 66
																	COND	56 56 %
																	FUNC	0
																	ECON	0
																	DEPR	56 % GD 44
																	RCNLD	\$273,800