

Key: 6110

Town of SCITUATE - Fiscal Year 2024

10/18/2023 5:31 pm SEQ #: 5.813

LEG
AL
LAND

CURRENT OWNER				PARCEL ID				LOCATION				
ADAMS MICHAEL A 55 TARA DRIVE NORWELL, MA 02061				51-2-8-0				108 EDWARD FOSTER RD				
TRANSFER HISTORY				DOS	T	SALE PRICE	BK-PG (Cert)					
ADAMS MICHAEL A				05/15/2015	O	1,150,000	(121819)					
108 EDWARD FOSTER RD, LLC				01/02/2015	F	100	(121433)					
ROSEN STEWART				10/30/2014	U	900,000	(121188)					
CD	T	AC/SF/UN	Ngh	Inf1	Inf2	ADJ BASE	SAF	Inf3	Lpi	VC	CREDIT AMT	ADJ VALUE
100	S	29,100	CLF	1.00	100	1,760,000	1.33	100	1.00	WF4	4.00	1,560,940

CLASS	CLASS%	DESCRIPTION		BN ID	BN	CARD	
1010	100	SINGLE FAMILY			1	1 of 1	
PMT NO	PMT DT	TY	DESC	AMOUNT	INSP	BY	1st %
22-0685	06/28/2022	3	ALTERATIONS	8,500	05/24/2023	NC	100 100
16-627	10/18/2016	3	ALTERATIONS	164,500	08/08/2017	SJ	100 100
16-83	02/19/2016	3	ALTERATIONS	30,000	08/01/2016	SJ	100 50
15-850	12/10/2015	2	ADDITIONS	35,000	08/01/2016	SJ	100 50
96-97	03/01/1996	2	ADDITIONS				100 100

LAND

TOTAL	29,098 SF	ZONING	FRNT	107	ASSESSED	CURRENT	PREVIOUS
Ngh	CLIFFS	NOTE			LAND	1,560,900	1,419,000
Inf1	FACTOR 100				BUILDING	1,571,500	1,297,900
Inf2	PHY 100				DETACHED	3,600	0
					OTHER	0	0
					TOTAL	3,136,000	2,716,900

DE
TA
CH
ED

TY	QUAL	COND	DIM/NOTE	YB	UNITS	ADJ PRICE	RCNLD
HTB	A	1.00	30 0.70		1	5,181.80	3,600

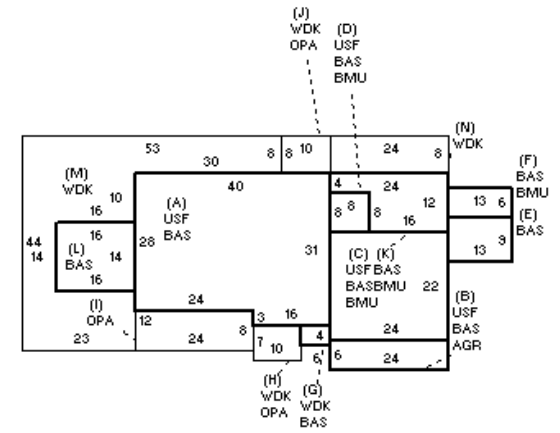

B
U
I
L
D
I
N
G

BUILDING	CD	ADJ	DESC	MEASURE	9/10/2009	PL
MODEL	1		RESIDENTIAL	LIST	9/10/2009	EST
STYLE	20	1.35	NEW STYLE [100%]	REVIEW	6/30/2023	MR
QUALITY	V	1.40	VERY GOOD [100%]			
FRAME	1	1.00	WOOD FRAME [100%]			

BLDG COMMENTS
ORIGINAL DWELLING BUILT 1973. MAJOR RENO.
1998 AND 2016/2017

YEAR BLT	1973	SIZE ADJ	1.000	ELEMENT	CD	DESCRIPTION	ADJ	S	BAT	T	DESCRIPTION	UNITS	YB	ADJ PRICE	RCN	TOTAL RCN	1,636,935
NET AREA	4,475	DETAIL ADJ	1.320	FOUNDATION	2	SLAB	0.95	+	BAS	L	BASE AREA	2,571	1973	334.63	860,335		
\$NLA(RCN)	\$366	OVERALL	1.000	EXT COVER	1	WD SHINGLES	1.00	+	USF	L	UPPER STORY FIN	1,904	1973	304.31	579,408		
				ROOF SHAPE	1	GABLE	1.00	B	AGR	N	ATT GARAGE	144		92.61	13,336		
				ROOF COVER	1	ASPH SHINGLES	1.00	+	BMU	N	BSMT UNFINISHED	894		68.25	61,018		
				FLOOR COVER	14	COMB	1.00	+	OPA	N	OPEN PORCH	342		72.10	24,658		
				INT FINISH	2	DRYWALL	1.00	+	WDK	N	WOOD DECK	1,394		53.76	74,942		
				HEATING/COOLING	9	WARM/COOL AIR	1.03		BMG	O	BSMT GARAGE	2		3,487.40	6,975		
				FUEL SOURCE	2	GAS	1.00										
																CONDITION ELEM	CD
																EXTERIOR	V
																INTERIOR	V
																KITCHEN	V
																BATHS	V
																HEAT	U
																ELECT	U
																EFF.YR/AGE	2018 / 4
																COND	4 4 %
																FUNC	0
																ECON	0
																DEPR	4 % GD 96
																RCNLD	\$1,571,500