

Key: 6160

Town of SCITUATE - Fiscal Year 2024

10/18/2023 5:31 pm SEQ #: 5.862

LEGAL

CURRENT OWNER				PARCEL ID				LOCATION			
FARIA MARY ELIZABETH, PETER J & KATHERINE C 18 BANK AVENUE HINGHAM, MA 02043				48-1-11-0				27 COUNTRY WAY			
TRANSFER HISTORY				DOS	T	SALE PRICE	BK-PG (Cert)				
FARIA MARY ELIZABETH,				02/21/2019	F		50828-251				
FARIA WALTER R & ANNA A				01/01/1968	QS		3403-19				
GILMAN FRANCIS P				01/01/1967	XX		3286-321				

CLASS	CLASS%	DESCRIPTION			BN ID	BN	CARD	
1040	100	TWO FAMILY				1	1 of 1	
PMT NO	PMT DT	TY	DESC	AMOUNT	INSP	BY	1st	%
05-765	11/15/2005	2	ADDITIONS	20,000	08/09/2006	SJ	100	100
05-765	11/15/2005	2	ADDITIONS	20,000	07/24/2007	SJ	100	100

LAND

CD	T	AC/SF/UN	Ngh	Inf1	Inf2	ADJ BASE	SAF	Inf3	Lpi	VC	CREDIT AMT	ADJ VALUE
100	S	30,000	GB	1.00	100	1.00	100	1.00	R02	0.85		332,710

TOTAL	30,013 SF	ZONING	FRNT	1,303	ASSESSED	CURRENT	PREVIOUS
Ngh	GREENBUSH	N O T E	IN M53	LAND	332,700	284,700	
Inf1	FACTOR 100		BUILDING	404,900	379,900		
Inf2	PHY 100		DETACHED	0	0		
			OTHER	0	0		
				TOTAL	737,600	664,600	

DETACHED

TY	QUAL	COND	DIM/NOTE	YB	UNITS	ADJ PRICE	RCNLD

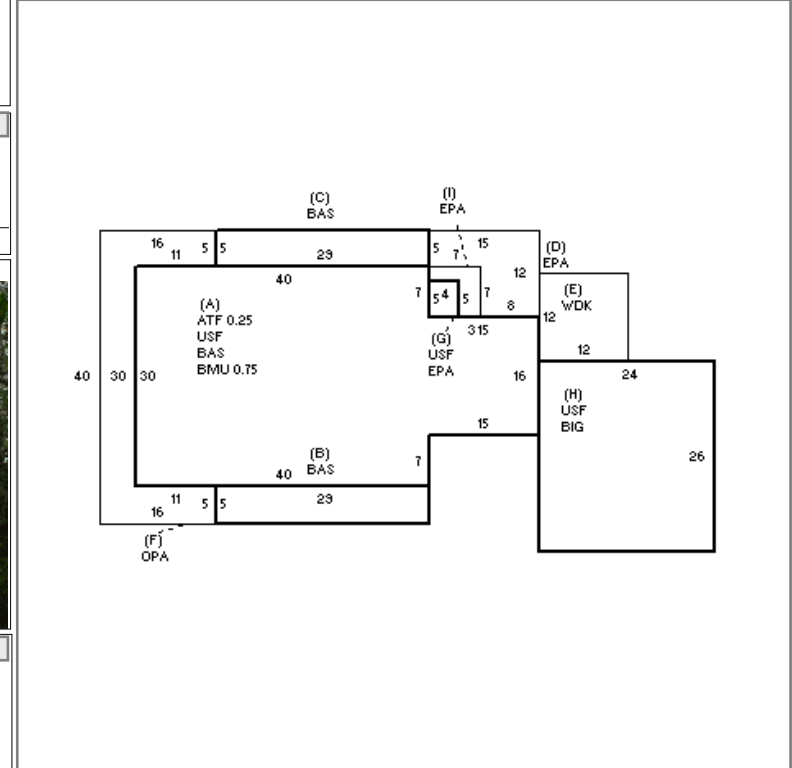

BUILDING

BUILDING	CD	ADJ	DESC	MEASURE		
MODEL	1		RESIDENTIAL	LIST		
STYLE	19	1.15	ANTIQUE [100%]	REVIEW	3/18/2011	ER
QUALITY	G	1.20	GOOD [100%]			
FRAME	1	1.00	WOOD FRAME [100%]			

BLDG COMMENTS
FY12 FR-COL TO ANTIQUE

G

YEAR BLT	1820	SIZE ADJ	1.000	ELEMENT	CD	DESCRIPTION	ADJ	S	BAT	T	DESCRIPTION	UNITS	YB	ADJ PRICE	RCN	TOTAL RCN	1,124,640			
NET AREA	4,174	DETAIL ADJ	1.147	FOUNDATION	4	CONT BSMT WALL	1.00	A	BMU	N	BSMT UNFINISHED	1,080		55.37	59,800	CONDITION ELEM	CD			
\$NLA(RCN)	\$269	OVERALL	1.000	EXT COVER	5	ASBESTOS	0.96	+	USF	L	UPPER STORY FIN	2,084	1820	227.97	475,092	EXTERIOR				
				ROOF SHAPE	1	GABLE	1.00	A	ATF	L	ATTIC FINISH	360	1820	161.97	58,309	INTERIOR				
				ROOF COVER	1	ASPH SHINGLES	1.00	+	BAS	L	BASE AREA	1,730	1820	250.69	433,686	KITCHEN				
				FLOOR COVER	2	SOFTWOOD	1.00	+	EPA	N	ENCLOSED PORCH	180		108.24	19,483	BATHS				
				INT FINISH	1	PLASTER	1.00	E	WDK	N	WOOD DECK	144		46.08	6,636	HEAT				
				HEATING/COOLING	2	HOT WATER	1.02	F	OPA	N	OPEN PORCH	310		61.80	19,158	ELECT				
				FUEL SOURCE	99	N/A	1.00	H	BIG	N	BUILT-IN GARAGE	624		57.66	35,982					
												F21	O	FPL 2S 1OP	1	9,886.80	9,887			
CAPACITY		UNITS	ADJ															EFF.YR/AGE	1952 / 70	
STORIES	2.25	1.00															COND	64	64 %	
ROOMS	12	1.00															FUNC	0		
BEDROOMS	6	1.00															ECON	0		
BATHROOMS	2	1.00															DEPR	64	% GD 36	
# 1/2 BATHS	0	1.00															RCNLD	\$404,900		
TOT FIXTURES	6	\$6,607																		
# UNITS	2	1.02																		